

### ATTENTION: READ THIS FIRST!

For more detailed installation, configuration, programming, and operating instructions, or for other wiring diagrams not shown here, refer to the *ViewStat Color Communicating Thermostat Operation/Reference Guide* available on-line at [www.amx.com](http://www.amx.com).



FIG. 1 ENV-VST-C ViewStat Color Communicating Thermostat

### Overview

The ViewStat Color Communicating Thermostat (FIG. 1) provides the current temperature (from an on-board sensor, a remote sensor, or an average of the on-board and remote sensors), controls and displays humidity, and displays the current outdoor temperature. The thermostat displays this information on a 3.5" (8.89 cm) color display. In addition, the thermostat provides the current day's weather forecast along with a five-day forecast, when connected to an Internet-enabled Master. The forecast information is driven from AMX's i!-Weather application. A three-year subscription to i!-Weather is included with purchase of the thermostat.

### Specifications

ViewStat Color Communicating Thermostat Specifications	
Control Voltage	24 VAC (interfaces with a power supply through the RC terminals.) <b>Warning:</b> Exceeding the control voltage may cause damage to the thermostat.
Switched Voltage	18-30 VAC, 57-63 Hz
Maximum Operating Current	2 amps total at rated voltage, through all outputs. 1 amp through any one output.
Maximum Surge Current	2.0 A
Internal Battery	CR2032 for maintaining real-time clock settings during a power loss.
Control Accuracy	±1.0° F (± 0.56° C) ±3% relative humidity
Temperature Range	Maximum displayable indoor temperature: 40°-99° F (5°-37° C) Maximum displayable outdoor temperature: -40°-120° F (-40°-49° C)
Operating Range	32°-122° F (0°-50° C)
Certifications	IC, FCC Class B, CE, and IEC60950
Front Panel Components:	
Main LCD display	3.5" (8.89 cm) color QVGA (320 x 240) Thin Film Transistor Liquid Crystal Display (TFT-LCD).
Navigation buttons	The Navigation buttons are used to change various parameters on the thermostat, including the temperature setpoints. These buttons are located beneath the display.
Mode/Select button	The Mode/Select button is used to navigate through the various thermostat screens, including the weather screens. This button is located beneath the display.

ViewStat Color Communicating Thermostat Specifications (Cont.)	
Circuit Board Components:	
Communication and HVAC Equipment connectors	Terminals with captive-wire connectors that connects to the thermostat, HVAC equipment, control system, remote sensors, and power supply.
Enclosure:	
Material	White plastic and removable front panel. Panel can be painted to match wall decor. <b>Warning:</b> If you paint the panel, do not paint over the exposed thermistor. Doing so can cause the external temperature sensor to work improperly.
Dimensions (HWD)	5.31" x 3.93" x 1.18" (13.48 cm x 9.98 cm x 2.99 cm)
Weight	5.29 oz. (150 grams)
Included Accessories	ENV-VST-C ViewStat Color Communicating Thermostat Installation Guide ( <b>93-2050-01</b> ) ENV-VST-TSO ViewStat Indoor/Outdoor Temperature sensor ( <b>FG2050-22</b> ) i!-Weather application ( <b>FG3005-20</b> ), three-year subscription
Optional Accessories:	ENV-VST-TSF ViewStat Indoor Flush Mount Temperature Sensor ( <b>FG2050-21</b> )

### Installing a Remote Sensor

Follow these steps to install the remote sensor:

1. Drill a 1/4" hole into the drywall where you want to install the sensor.
2. Fish the cable that connects to the sensor through the 1/4" hole in the wall until the edge of the sensor, where the cord meets the sensor, is flush against the wall.
3. Apply caulk, drywall putty, insulation, or any other appropriate sealant to the hole in the wall around the sensor to seal the hole.
4. Attach the connecting wires from the sensor to the S1 and S2 terminals on the thermostat.

**Note:** You can use a maximum of 300 ft (91.44 m) of 18 AWG wire for connecting the indoor/outdoor remote sensor to the thermostat.

The thermostat automatically defaults to using the on-board temperature sensor when you install it. For information about activating the remote sensor, consult the *Activating the External Sensor* section of the *ViewStat Color Communicating Thermostat User Guide*.

### Mounting the Base to a Wall

You should only mount the thermostat onto a sheetrock wall with the anchors and screws provided with the unit. There are four screw holes located on the base of the thermostat. No tools are required to disassemble the thermostat—simply use your hands to pull the front panel off of the base.

1. Place the base over the wire hole opening in the wall. Level the base (leveling required for appearance only) and mark the screw hole mounting locations.
2. Using the supplied wall anchors, drill 1/4" hole in the center of the marked locations, and tap the wall anchors into the holes. If using the supplied screws only, drill a 3/32" hole in the center of the marked locations.

**Note:** Minimize the wire entry hole size and seal. Drafts from inside the wall could affect temperature readings.

3. Fasten the base to the wall with the supplied screws.
4. Seal the wire entry with caulk, drywall putty, or insulation.

### Wiring the Thermostat

**Note:** A qualified HVAC technician should perform these steps to ensure proper termination.

1. Make sure the HVAC system power is off.
2. Strip 1/4" (0.63 cm) of insulation from each wire you are using.
3. Secure the wires into the terminals on the base according to the appropriate wiring diagram. Use color-coding practices (i.e. white wire to W terminal) whenever possible.
4. Check each wire to ensure it is securely fastened, not broken, and any exposed wires are not touching each other.

## Wiring for AxLink

Follow these steps to connect the wiring into a captive-wire connector:

1. Strip 1/4 inch off the wire insulation for all four wires.
2. Tin 2/3 of the exposed wire.
3. Insert each wire into the appropriate captive-wire connector up to the insulation.
4. Tighten the captive screws to secure the fit in the connector.

Use 18 AWG wire to connect the AxLink wiring from the thermostat to the connector on the AxLink device as shown in FIG. 2.

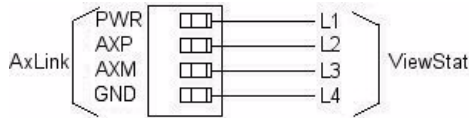

FIG. 2 AxLink wiring

**Note:** The ViewStat Color Communicating Thermostat interfaces with a 24 VAC power supply from the heating/cooling unit through its RC terminal. You should not connect the power wiring from the AxLink device to the thermostat with the intent of using the AxLink device to provide power to the thermostat. The L1 terminal on the thermostat can accept the AxLink +12VDC wire and you can connect the wire to the terminal if you want to assure there are no loose wires inside the thermostat, but you should not power the thermostat by running a jumper to the RC pin.

## Wiring Diagrams

ViewStat Color Communicating Thermostats are equipped with terminals RC, RH, C, Y, W, G, O, B, S1, S2, L1, L2, L3, and L4. You can use terminals S1 and S2 to accommodate a remote temperature sensor. Terminals L1-L4 connect to the AxLink cable. The remaining terminals are used to control various types of heating and cooling systems. You can use the thermostat with the following types of heating and cooling systems:

- Single Stage Furnace and Single Stage A/C
- Dual Stage Furnace and Dual Stage A/C
- Roof Top Unit with Dual Stage Heat and Dual Stage Cool
- Boiler with A/C with Separate Transformers
- Single Stage Heat Pump
- Two Stage Heat Pump
- First Stage Radiant Floor Heat, Second Stage Furnace One Stage of Cooling

## Communication and Equipment Terminal Wiring Definitions

FIG. 3 displays the terminal layout for the thermostat.

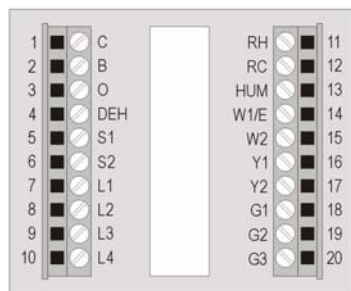

FIG. 3 Terminal Layout

The following table lists the communication and equipment terminal wiring definitions:

Communication and Equipment Terminal Wiring Definitions	
RH	24 VAC in
RC	24 VAC in for AC relays. If a separate 24 VAC is not supplied to the RC terminal, you should install a jumper from RH to RC.
C	24 VAC common
G1	Fan on 1. If you are using a single speed fan, you can connect it to the G1 terminal, but you must set the fan speed to Low. On a multi-speed fan, G1 is the lowest speed.
G2	Fan on 2. On a multi-speed fan, G2 is the medium speed.
G3	Fan on 3. If you are using a single speed fan, you should connect it to the G3 terminal. On a multi-speed fan, G3 is the highest speed.
W1	1st stage heat
W2	2nd stage heat

## Communication and Equipment Terminal Wiring Definitions (Cont.)

Y1	1st stage compressor
Y2	2nd stage compressor
B	Reversing valve (heat)
O	Reversing valve (cool)
DEH	Dehumidify
HUM	Humidify
S1	External thermistor. The ViewStat Color Communicating Thermostat supports only one external sensor.
S2	External thermistor. The ViewStat Color Communicating Thermostat supports only one external sensor.
L1	AxLink PWR
L2	AxLink AxP
L3	AxLink AxM
L4	AxLink GND

**Warning:** Applying voltage to the external temperature sensor pins (S1 and S2) can cause permanent damage to the thermostat.

## Single Stage Furnace and Single Stage A/C

FIG. 4 displays the thermostat wiring for a system with a single stage furnace and A/C.

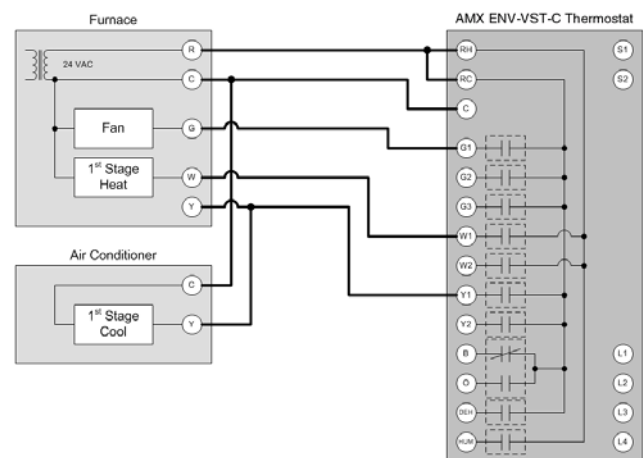

FIG. 4 Single Stage Furnace and Single Stage A/C wiring

The thermostat automatically defaults to One Stage Furnace for the HVAC System setting when you install it. For information about changing the HVAC System setting, consult the *Changing the Type of HVAC System* section in the *ViewStat Color Communicating Thermostat User Guide*.

## Dual Stage Furnace and Dual Stage A/C

FIG. 5 displays the thermostat wiring for a system with a dual stage furnace and A/C.

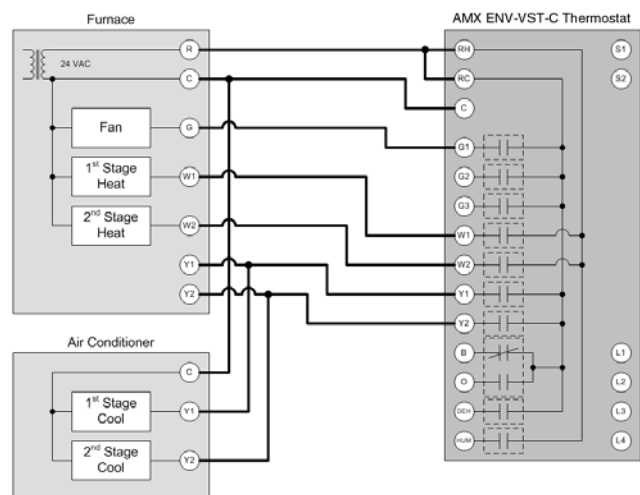

FIG. 5 Dual Stage Furnace and Dual Stage A/C wiring

For full warranty information, refer to the AMX Instruction Manual(s) associated with your Product(s).

10/09

©2009 AMX. All rights reserved. AMX and the AMX logo are registered trademarks of AMX.

AMX reserves the right to alter specifications without notice at any time.

3000 RESEARCH DRIVE, RICHARDSON, TX 75082 • 800.222.0193 • fax 469.624.7153 • technical support 800.932.6993 • www.amx.com

93-2050-01 REV: H

