

**Total installed
cost comparison
study of motorized
shading systems**

line voltage AC system
vs. low voltage
Sivoia QED® system

Technical white paper
December 2008

Introduction

In this study, the word “cost” refers to what the end user pays for any particular item. The total installed cost of a motorized shading system₁ includes component, wiring, and labor costs. Each type of system may be sold by different contractor types (see Table 1). Due to radically different designs, the shading system must be specified and designed before any wiring and labor quotes can be obtained. Consequently, decision makers often compare and select systems based only on components costs, without considering wiring and labor costs until after the motorized shading system has been chosen.

Goods and services sold by contractor type

Contractor type	Line voltage AC shading system ₂	Low voltage Sivoia QED® shading system ₃
Window treatment contractor	<ul style="list-style-type: none"> Shading components Installation labor 	<ul style="list-style-type: none"> Shading components Installation labor Low voltage cable Wiring labor
Electrical contractor	<ul style="list-style-type: none"> Line voltage cable Wiring labor 	<ul style="list-style-type: none"> Line voltage cable Low voltage cable Wiring labor

Table 1 – Comparison of goods and services that each provider offers for line voltage AC and low voltage Sivoia QED shading systems

Wiring and labor are critical factors to consider in cost comparisons for two reasons. First, they represent a significant portion of the total installed cost. And second, these costs vary significantly between motorized shading system types due to radically different designs. Decision making based strictly on component costs can mislead project managers to select a more expensive total solution.

The intent of this study is to compare the total installed costs of line voltage AC₂ and low voltage Sivoia QED₃ shading systems. This comparison method will allow decision makers to maximize total cost savings and to better assess the value created by the intangible features of these systems.

¹ **Motorized shading system:** electrical circuits, processors, motors and/or drives that work together as a system to control window shades

² **Line voltage AC shading system:** analog motorized shading system that uses 120V AC electrical motors to operate window shades. Motors are powered and controlled by devices called group controllers. The grouping and operation of the shades is determined by hard-wired connections between the motors and specific inputs/outputs on the group controllers. Line voltage cable is required to connect the motors to the group controllers and to power the system.

³ **Low voltage Sivoia QED system:** digital motorized shading system that uses 24V AC electronic drive units (EDU) to precisely control window shades. EDUs receive power from either low-voltage power panels or individual power supplies. The grouping and operation of the EDUs in the system is programmable and does not require rewiring for changes in system configuration. Low voltage cable is used for communication and powering of the shades. Line voltage cable is only required to provide power to the power panels or power supplies.

Execution details

This study compared a total installed cost of line voltage AC against low voltage Sivoia QED® shading systems.

Data gathering

- A commercial office floor plan was selected (see pages 4-5)
- Line voltage AC and low voltage Sivoia QED shading systems were designed to meet site and client requirements (see pages 4-5)
- Fabric, lineals, mounting hardware, and control requirements were kept consistent between systems when possible
- Component, wiring, and labor quotes were obtained from both window treatment[†] and electrical contractors in different regions of the United States

Assumptions

- Cost savings were preferable and therefore, whenever a quote was offered by two or more contractors, the lowest was selected
- All window treatment contractors applied an equal markup above net cost for both line voltage AC and low voltage Sivoia QED components

Scenarios

To account for the cost savings vs. control flexibility tradeoff, three different implementation scenarios were analyzed (see Table 2). At the expense of control flexibility, coupling₄ shades reduces the cost of the system by using fewer operators₅ and less wiring.

Description of scenarios

Scenario	Coupling Method	Total # of Operators	Operator Type	Tube Diameter
Maximized coupling (MAX) ^A	As much as possible	15	AC 120v LT	2.5 in
			Sivoia QED roller 200CW or roller 100™	2.5 in
Coupled pairs (COUPLE) ^B	Each pair	23	AC 120v LT	2.5 in
			Sivoia QED roller 100	2.5 in
Independent shades (INDIE) ^C	N/A	46	AC 120v LT	2.5 in
			Sivoia QED roller 64™	1.625 in

Table 2 – Implementation scenarios representing the typical tradeoff between total installed cost savings and control flexibility

[†] All window treatment contractors in this study sell both line voltage AC and low voltage Sivoia QED shading systems.

⁴ **Coupling:** method of controlling two or more shades together using only one operator. When shades are coupled, the user can no longer control individual shades independently.

⁵ **Operators:** electric motor (line voltage AC) or electronic drive unit (low voltage Sivoia QED) used to operate shades.

^A **MAX** – For the open office area, shades were coupled in groups of 4 (1 operator per every 4 shades). In the conference rooms and the executive office, shades were coupled in groups of 2 (1 operator per every 2 shades). This set-up represents the maximum coupling possible based on the project's constraints.

^B **COUPLE** – All shades were coupled in groups of 2 (1 operator per every 2 shades).

^C **INDIE** – Each individual shade utilizes its own respective operators (1 operator per shade). The operators for this case were selected to best fit the parameters of each window.

Less
↑
Control Flexibility/
Cost
↓
More

Project Floor Plan

3rd Level

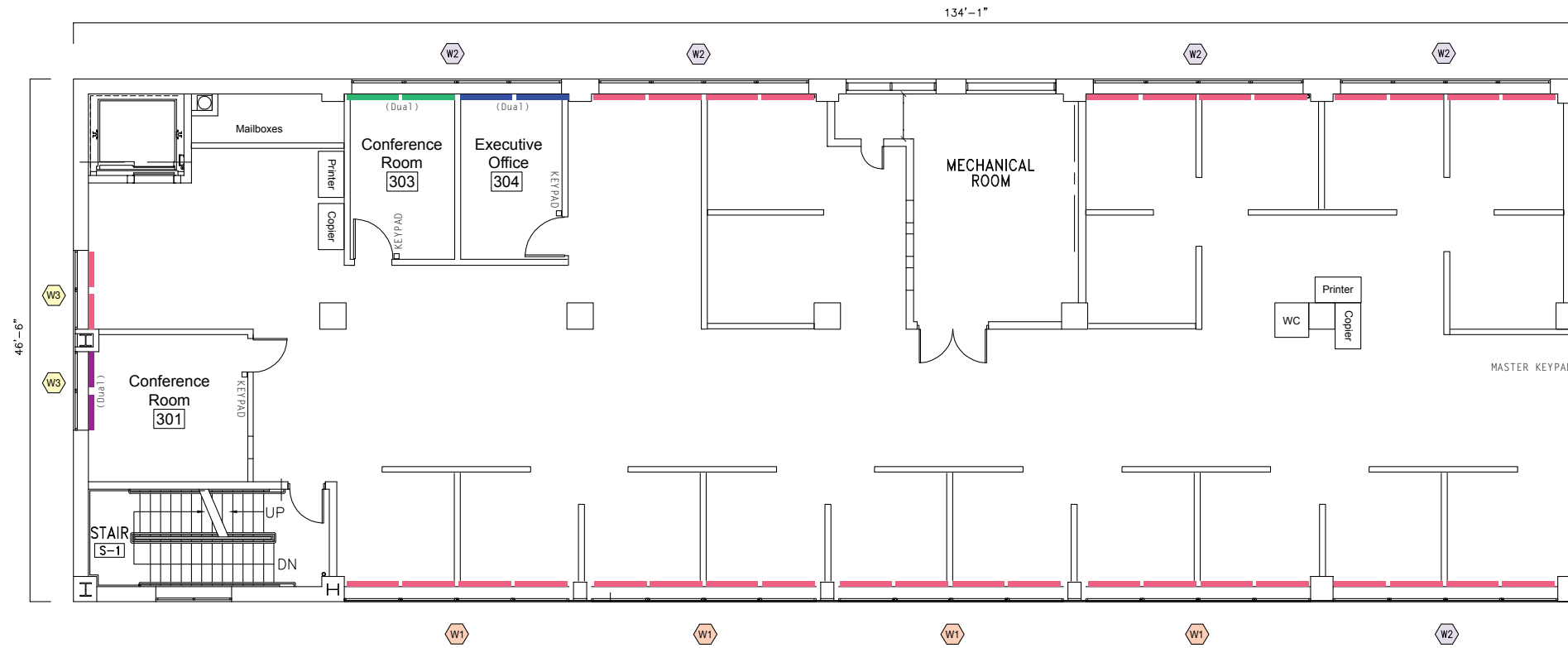
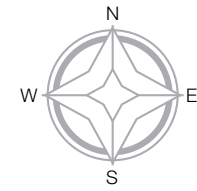

Area shading and control specifications

Color key	Area name	Shading requirements	Shade groups	Number of keypads	Total number of shades
	Open Office	Sheer shades	North+West South Master	1	34
	Conference Room - 301	Dual (sheer + blackout)	Sheers Blackouts Both	1	4
	Conference Room - 303	Dual (sheer + blackout)	Sheers Blackouts Both	1	4
	Executive Office - 304	Dual (sheer + blackout)	Sheers Blackouts Both	1	4

Fabric specifications

Shading System	Sheers (3%*)	Blackouts (0%*)
Line voltage AC	Solar Fabric 6000 Series	Blackout Fabric 100 Series
Low voltage Sivoia QED®	Basketweave XL2	Flocke Blackout

*Openness factor (percent of light coming through fabric)

Window types and dimensions

Window type	Number of panels per window	Shade dimensions (bracket to bracket)
W1	4	76 in. h x 60 in. w
W2	4	76 in. h x 56 in. w
W3	2	76 in. h x 42 in. w

General specifications

- Hembar Appearance: Exposed
- Lineals: Fascia with top/back cover where possible, pocket otherwise
- Metal Finish: Anodized aluminum
- Fabric Drop: Regular (fabric closest to window)

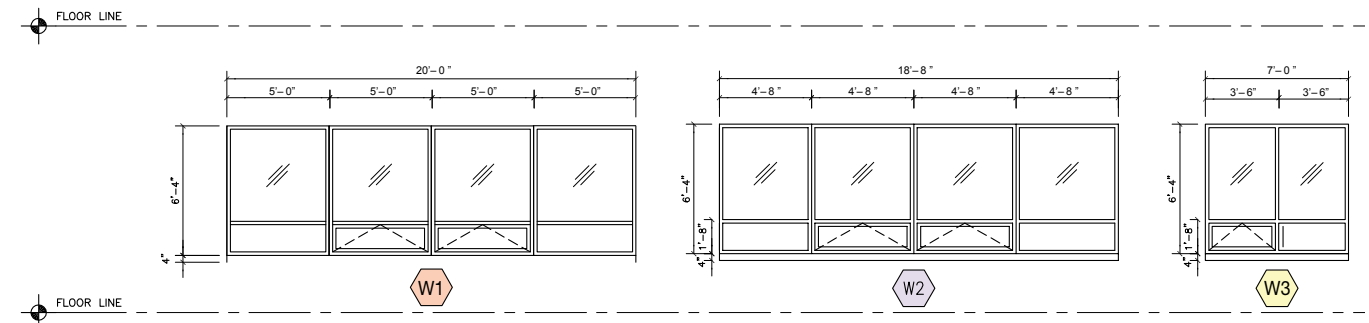

Summary of Results

A total installed cost comparison was executed for each of the three scenarios mentioned in Table 2 of this report. The results of the total installed cost comparisons are shown in Figure A. Detailed costs for components, labor, and wiring can be found on Table 3.

In both the coupled pairs (COUPLE) and independent shades (INDIE) scenarios, the low voltage Sivoia QED® shading system's total installed cost was lower by 4% and 25% respectively. On the maximized coupling (MAX) scenario, despite the fact that component costs were 41% higher, the total installed cost was only 4% higher for the low voltage Sivoia QED shading system.

On average across all three cases, wiring and labor costs were lower by 57% and 32% respectively for the low voltage Sivoia QED shading system (see Table 3).

This is the direct result of two factors related to the use of low voltage wiring:

- 62.5% (\$0.65) lower cost per foot of the cable
- 52% (\$0.58) lower labor cost per foot to install

These cost differentials are very important, due to the significant portion of the total cost that wiring and labor represented as it is shown in figure B.

System costs

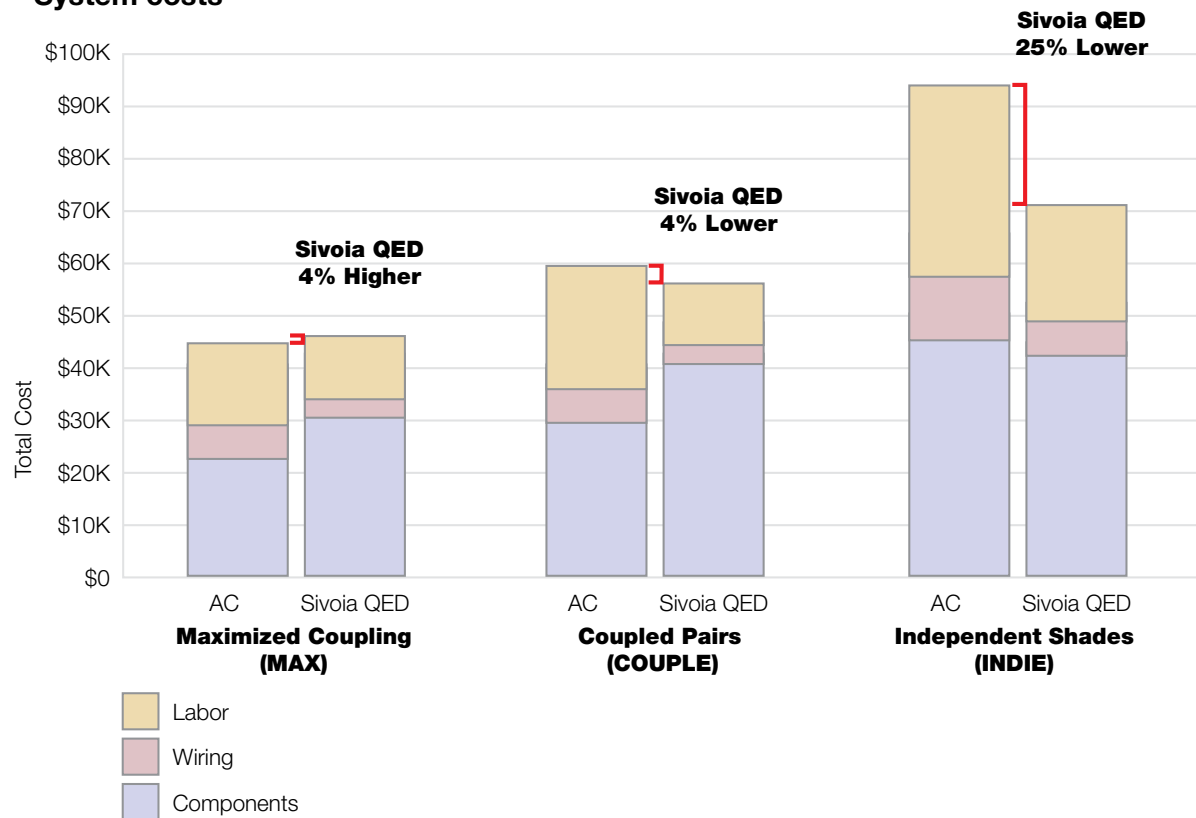

Figure A – Comparison of cost aspects for the line voltage AC and low voltage Sivoia QED shading systems

Summarized total installed cost

Maximized Coupling (MAX) Scenario				
Aspect	Aspect Cost		Cost Differential (\$)	Cost Differential (%)
	AC	Sivoia QED®		
Labor	\$17,061.55	\$12,173.79	\$(4,887.75)	-29%
Wiring	\$4,543.65	\$1,921.45	\$(2,622.19)	-58%
Components	\$23,473.58	\$32,991.59	\$ 9,518.00	41%
Total	\$45,078.78	\$47,086.83	\$2,008.06	4%

Coupled Pairs (COUPLE) Scenario				
Aspect	Aspect Cost		Cost Differential (\$)	Cost Differential (%)
	AC	Sivoia QED		
Labor	\$24,040.19	\$16,239.78	\$(7,800.41)	-32%
Wiring	\$6,630.37	\$2,844.64	\$(3,785.73)	-57%
Components	\$27,992.45	\$37,456.13	\$9,463.67	34%
Total	\$58,663.01	\$56,540.55	\$(2,122.46)	-4%

Independent Shades (INDIE) Scenario				
Aspect	Aspect Cost		Cost Differential (\$)	Cost Differential (%)
	AC	Sivoia QED		
Labor	\$37,645.62	\$24,912.86	\$(12,732.75)	-34%
Wiring	\$12,648.62	\$5,437.88	\$(7,210.74)	-57%
Components	\$44,090.57	\$40,261.84	\$(3,828.72)	-9%
Total	\$94,384.80	\$70,612.59	\$(23,772.22)	-25%

Table 3 - Comparison between component cost differentials and total installed cost differentials

Average total cost distribution



Figure B – Average cost distribution of all three scenarios

Line Voltage AC
Coupled Pairs (COUPLE) Scenario

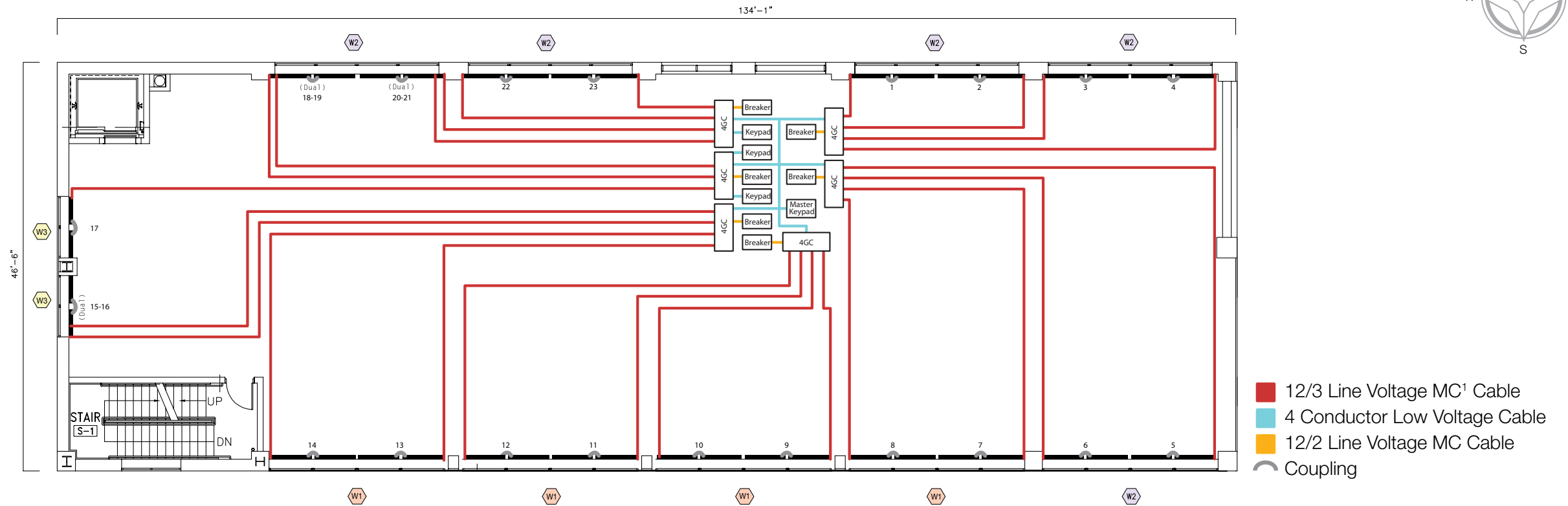
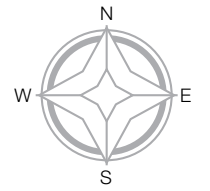

Table 4 - AC Project Costs

			Qty	Total Price (USD)
Labor	Window Treatment Contractor	Administrative Charges	-	\$1,950.00
		Keypad Cable Labor	-	\$400.00
		Shades Installation and Programming	-	\$11,518.00
	Electrical Contractor	Line voltage wiring and circuit installation	-	\$10,172.19
Total Labor				\$24,040.19
Wiring	Breakers & Electrical Materials	20 A Breakers	6	\$157.15
		Miscellaneous Materials	-	\$2,099.59
	Cable (Qty. in feet)	#12/3 MC Cable (Shades Wiring)	2300	\$3,878.69
		#12/2 MC Cable (Breaker Wiring)	300	\$301.34
		Low Voltage 4 Conductor Keypad Cable	400	\$193.60
Total Wiring				\$6,630.37
Components	Shades, Brackets and Lineals	Open Office Sheer Shade Pairs	17	\$18,464.15
		Conference Rooms & Executive Office Dual Shade Pairs	6	\$6,950.94
		Keypads	Group A, B, A+B Keypads	4
	Power and Control	Group Controllers	6	\$2,207.55
	Total Components			
Total Installed Cost				\$58,663.01

1. Metal clad (MC): MC cables are equivalent to using conduit and regular line voltage cable

Summary

In many cases, line voltage AC shading system components are less expensive than low voltage Sivoia QED® shading system components. Despite this, there are other significant cost adders that must be accounted for. These include the dedicated circuit breakers required for group controllers, wiring materials, and labor. In the coupled pairs (COUPLE) scenario, wiring and labor represent 52% of the total cost.

The line voltage AC shading system wiring diagram for the COUPLE scenario shown above describes how the system is connected and the type of wiring required. One circuit breaker was required for each of the 6 group controllers. For this project, the quoted cost for 12/3 MC¹ cable utilized to wire the shades was \$1.69/foot. Furthermore, line voltage wiring can only be installed by a certified electrician. The electrician's labor quote for wiring the shades in this specific project was 1.69 labor-\$/foot.

Low Voltage Sivoia QED®
Coupled Pairs (COUPLE) Scenario

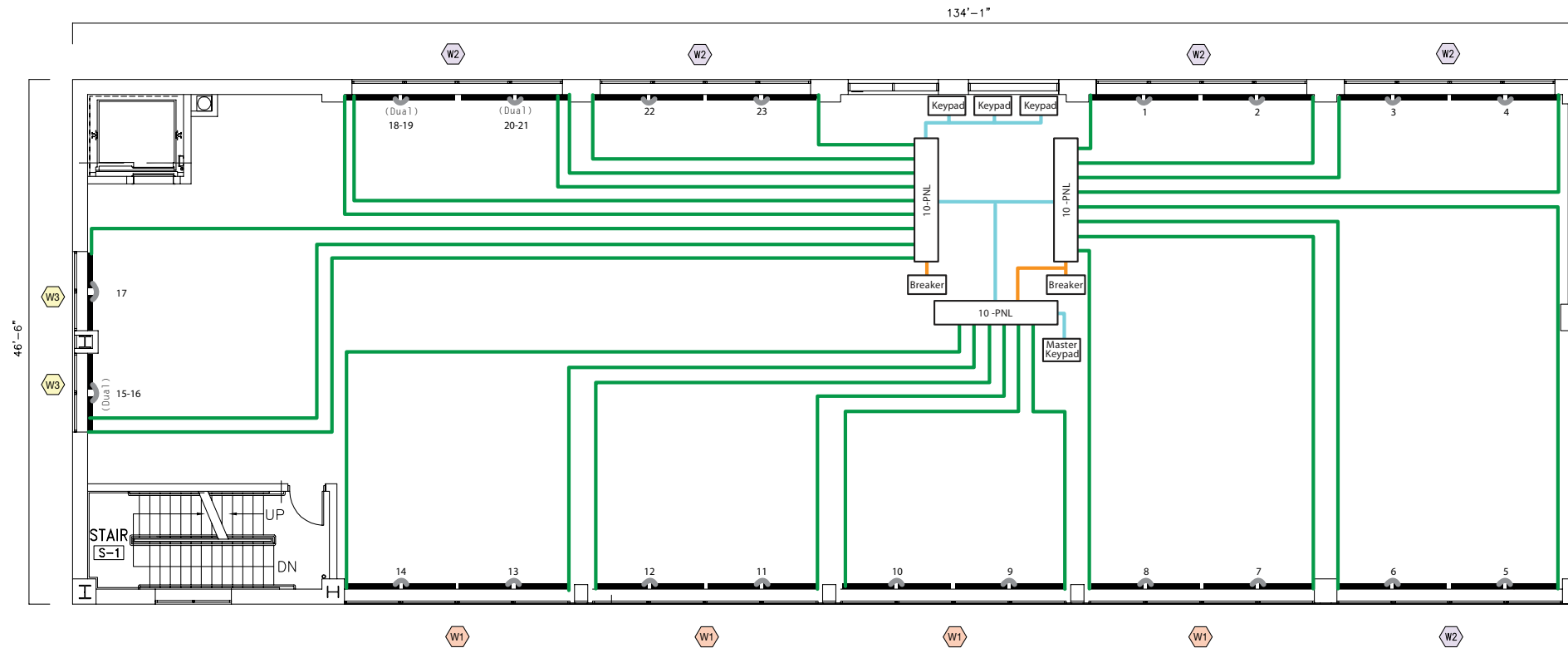
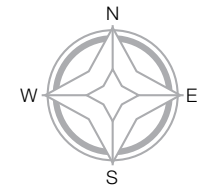

- 7 Conductor Low Voltage Cable
- 4 Conductor Low Voltage Cable
- 12/2 Line Voltage MC₁ Cable
- Coupling

Table 5 - Sivoia QED® project costs

			Qty	Total Price (USD)
Labor	Window Treatment Contractor	Administrative Charges	-	\$2,515.00
		Low voltage shade and keypad wiring	-	\$3,000.00
		Shades Installation and Programming	-	\$10,203.00
	Electrical Contractor	Line voltage wiring and circuit installation	-	\$521.78
	Total Labor			
Wiring	Breakers & Electrical Materials	20 A Breakers	2	\$52.38
		Miscellaneous Materials	-	\$98.21
	Cable (Qty. in feet)	#12/2 MC Cable (Breaker Wiring)	100	\$100.45
		Low Voltage 7 Conductor Cable (shades wiring)	2300	\$2,400.00
		Low Voltage 4 Conductor Keypad Cable	400	\$193.60
Total Wiring				\$2,844.64
Components	Shades, Brackets and Lineals	Open Office Sheer Shade Pairs	17	\$24,130.63
		Conference Rooms & Executive Office Dual Shade Pairs	6	\$10,094.67
	Keypads	Group A, B, A+B Keypads	4	\$957.00
	Power and Control	10-PNL Power Panels	3	\$2,273.83
	Total Components			
Total Installed Cost				\$56,540.55

Summary

The cost comparison of system components does not take into account the radically different wiring and labor requirements of a low voltage Sivoia QED® shading system. By design, the Sivoia QED system can power up to 2 power panels through 1 circuit breaker, controlling a maximum of 20 shades per breaker. Furthermore, it utilizes low voltage cable to connect the shades. In the coupled pairs (COUPLE) scenario, wiring and labor represent only 34% of the total installed cost of the low voltage Sivoia QED shading system.

The low voltage Sivoia QED shading system wiring diagram for the COUPLE scenario shown above describes how the system is connected, as well as the type of wiring required. The system design allows up to 10 shades to be powered and controlled through each 10-PNL power panel. This project requires only 2 circuit breakers and 100 feet of line voltage 12/2 MC₁ cable. For this project, the quoted cost for 7 conductor low voltage cable utilized to wire the shades was \$1.04/foot. Furthermore, low voltage wiring can be installed by either a certified electrician or a window treatment contractor. The window treatment contractor's labor quote for wiring the shades in this specific project was 1.11 labor-\$/foot.

Conclusion

Based on the results of this study, it can be concluded that the relative component cost difference is a misleading indicator of the relative total installed cost difference between the two systems (see Table 6). To assume that the component cost differential is representative of the total system is, in fact, significantly overestimating the premium or underestimating the savings that low voltage Sivoia QED® shading systems can help achieve.

Summary of relationship between component and total installed cost differentials

Scenario	Relative component cost of low voltage Sivoia QED over line voltage AC	Relative total installed cost of low voltage Sivoia QED over line voltage AC
Maximized coupling (MAX)	41% Premium →	4% Premium
Coupled pairs (COUPLE)	34% Premium →	4% Savings
Independent shades (INDIE)	9% Savings →	25% Savings

Table 6 – Relative cost comparison

In conclusion, **making cost-motivated decisions based on component cost comparisons alone may be misleading and could drive a decision maker to pick a more expensive total system.** Therefore, in order to make a well informed decision, it is critical to always compare shading systems on the basis of total installed cost, including components, as well as wiring and labor.

Going beyond the costs

Above and beyond the potential total cost savings that can be achieved by utilizing low voltage Sivoia QED® shading systems, there are clearly differentiated intangible benefits tied to low voltage Sivoia QED shading systems that provide significant value to the customer.

Aesthetics

- Minimal, symmetrical light gaps
- Elegant control options
- Wide array of fabrics
- Integration with Lutron® light control systems for total light control

Control

- Ultra-quiet electronic drive
- Intelligent hembar alignment™
- Built-in infrared capability

Flexibility and performance

- Limits and presets never lost
- Sustainable design and LEED contribution
- Superior system warranty and support

Installation

- Simple reconfiguration without rewiring or addition of group controllers
- Local programming from a keypad or handheld control

Line voltage AC wiring diagram

Coupled pairs (COUPLE) scenario

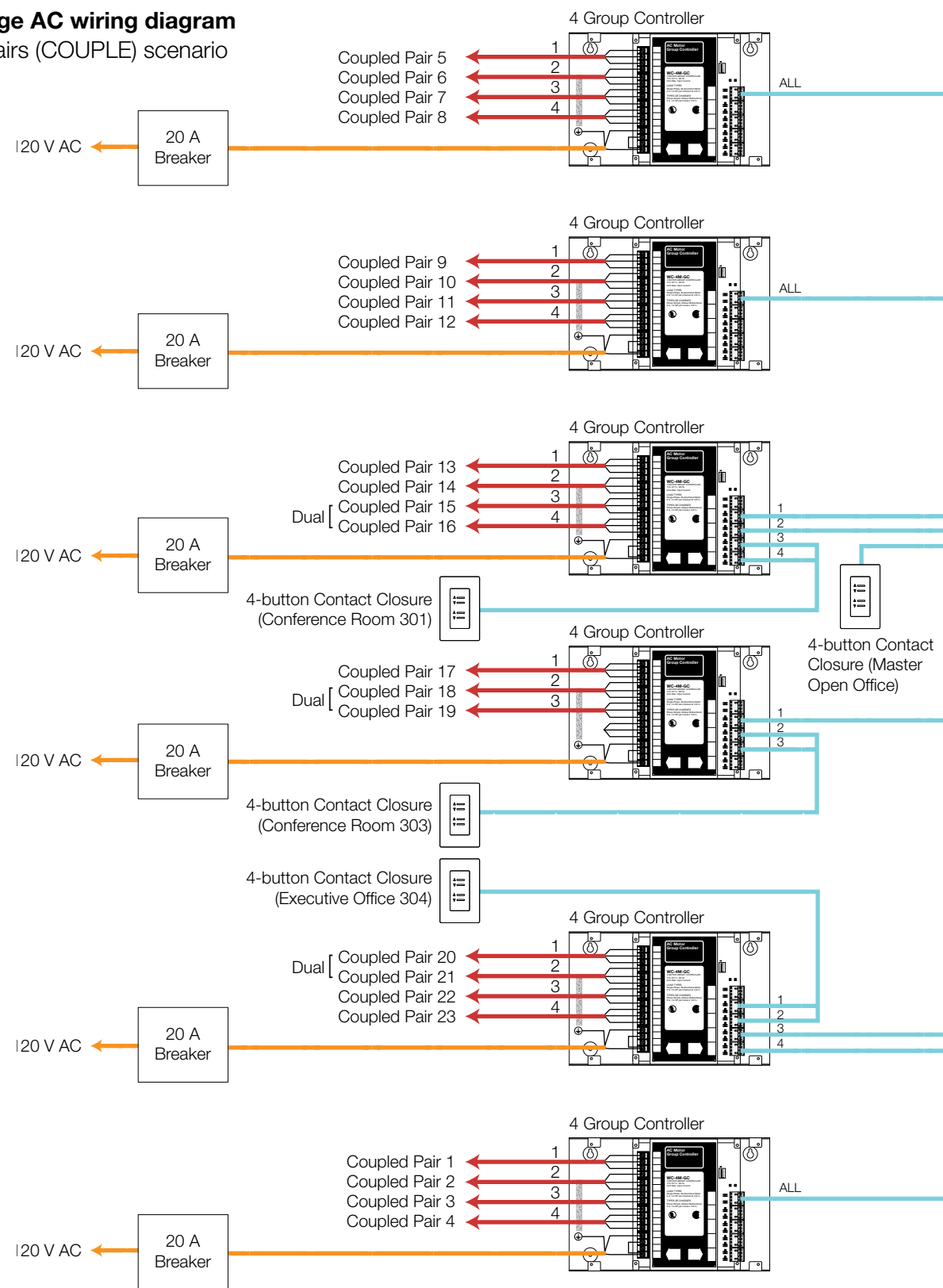

- 12/3 Line Voltage MC Cable
- 4 Conductor Low Voltage Cable (Communication link-shielded)
- 12/2 Line Voltage MC Cable (Input Power)

Low Voltage Sivoia QED® wiring diagram

Coupled pairs (COUPLE) scenario

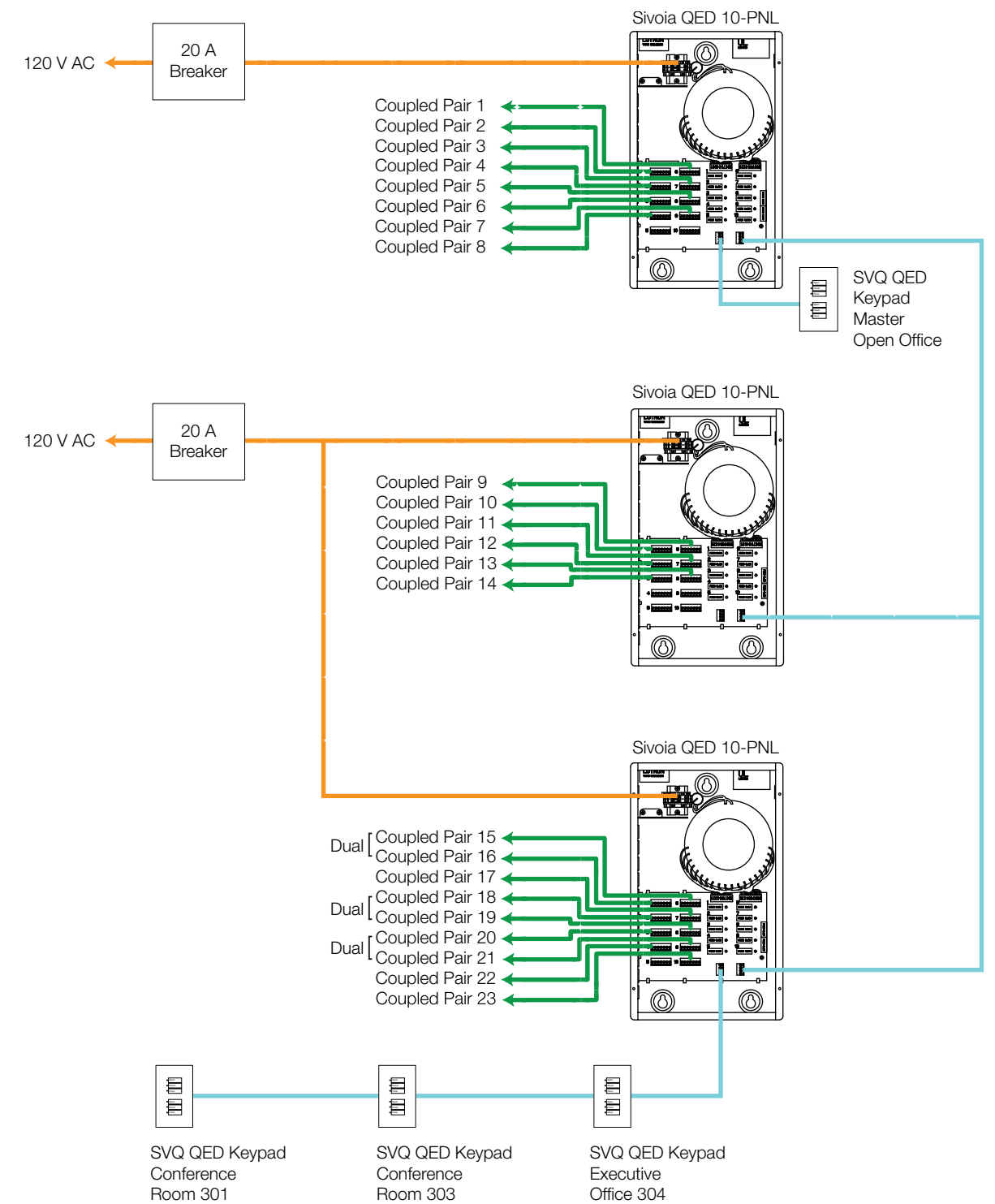

- 7 Conductor Low Voltage Cable (SVQ-CBL-250)
- 4 Conductor Low Voltage Cable (Communication link-shielded)
- 12/2 Line Voltage MC Cable (Input Power)



Customer Service/Quotes: 1.800.446.1503
Technical Support Center: 1.800.523.9466

For more information about Sivoia QED®
shading systems, contact your local Lutron
representative, or visit us on the web
at www.lutron.com/shadingsolutions

World Headquarters
Lutron Electronics Co., Inc.
7200 Suter Road
Coopersburg, PA
18036-1299 USA