

SONANCE

COMMERCIAL SOLUTIONS



SONANCE IPÖRT



Sonance, James Loudspeaker and IPÖRT have been providing solutions for commercial environments for decades, delivering a unique blend of aesthetics, performance and functionality that enhance both the design and utility of any commercial space.

DESIGNED TO DISAPPEAR

Technology should disappear into architecture...this simple philosophy continues to inspire everything we do. Our hidden audio solutions deliver an even, balanced sound experience that is nothing short of magical, blending into any style, installation, or budget.

AUTHENTIC PARTNERSHIP

Every day at our home base in San Clemente, CA, you will find passionate, immensely knowledgeable people forging some of the strongest relationships in our industry. From our customer-centric culture to our not-to-be-missed Studio Seminars, we aim to define what authentic partnership looks like. Connecting our strategy and products to your company, we help unlock the most value possible for your business. *Our team is your team.*

A HERITAGE OF INNOVATION

The history of our independently-owned company is rooted in a deep knowledge of our customers and construction. From award-winning audio solutions to our unique TRUFIG mounting technology to our IPÖRT solutions that hold, charge, and protect tablets, customers rely on our culture of creativity to continue to push the boundaries of technology and design.

SONANCE PROFESSIONAL SERIES



Sonance Professional Series has become a game-changer for commercial audio, delivering clean aesthetics, excellent sonic performance, and consistent tonality across its form factors. Available in in-ceiling, pendant, and surface mount speakers, Sonance Professional Series speakers are perfect for boardrooms, retail, hotels, restaurants, houses of worship, education, gyms, casinos, car dealerships, or anywhere requiring a high quality 70V/100V loudspeaker.

WHERE YOU CAN FIND US



HOSPITALITY



CORPORATE



RETAIL



EDUCATION



HOUSES OF WORSHIP



IN-CEILING SPEAKERS

Sonance Professional Series In-Ceiling Speakers feature a bezel-less grille design and optional square grilles ensuring minimal visual intrusion, whilst also matching design cues of lighting and decor. Sonance's Laminated Core Transformer combined with state-of-the-art driver design deliver best-in-class fidelity and uncompromised sonic performance in 70V/100V.

CLEAN LOOK. CLEAN SOUND.



- UL 1480 and UL 2043 certified
- Euroblock connector with loop through
- Sonance Laminated Core Transformer for uncompromised sonic performance in 70V/100V
- Heavy-duty voice coils for reliability and longevity
- High excursion Polypropylene woofer for effortless bass response
- Pivoting 1" soft dome chambered tweeter to direct sound for accurate coverage
- Magnetic grille retention for easy installation

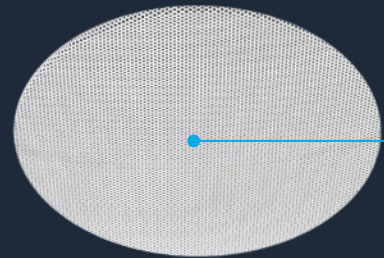

One-piece bezel-less grille (Also available in black)



Optional square adapter with black or white grille, provides aesthetic to match lighting and decor.

SPECIFICATIONS



	PS-C43RT	PS-C63RT	PS-C83RT	PS-C83RWT	PS-C43RTL (LOW PROFILE)	PS-C63RTL (LOW PROFILE)
Tweeter	1" (25mm) cloth dome, pivoting	1" (25mm) cloth dome, pivoting	1" (25mm) cloth dome, pivoting	N/A	1" (25mm) cloth dome, pivoting	1" (25mm) cloth dome, pivoting
Woofer	4" (100mm) poly cone, rubber surround	6.5" (165mm) poly cone, rubber surround	8" (203mm) poly cone, rubber surround	8" (203mm) poly cone, rubber surround	4" (100mm) poly cone, rubber surround	6.5" (165mm) poly cone, rubber surround
Frequency Range +/-3dB	75Hz - 20kHz	65Hz - 20kHz	55Hz - 20kHz	50Hz - 150Hz	75Hz - 20kHz	65Hz - 20kHz
Power Handling RMS	60W program, 30W pink noise	120W program, 60W pink noise	160W program, 80W pink noise	300W program, 150W pink noise	60W program, 30W pink noise	120W program, 60W pink noise
Sensitivity	87dB	91dB	91dB	89dB	87dB	91dB
Transformer Taps	30W, 15W, 7.5W, (3.8W 70V), 8 Ohm	60W, 30W, 15W, (7.5W 70V), 8 Ohm	60W, 30W, 15W, (7.5W 70V), 8 Ohm	120W, 60W, 30W, (15W 70V), 8 Ohm	30W, 15W, 7.5W, (3.8W 70V), 8 Ohm	60W, 30W, 15W, (7.5W 70V), 8 Ohm
Impedance	8 Ohms nominal	8 Ohms nominal	8 Ohms nominal	8 Ohms nominal	8 Ohms nominal	8 Ohms nominal
Termination	Removable locking clip-in connector	Removable locking clip-in connector	Removable locking clip-in connector	Removable locking clip-in connector	Removable locking clip-in connector	Removable locking clip-in connector
Included Accessories	C-ring & tile bridge, cutout template, white grille	C-ring & tile bridge, cutout template, white grille	C-ring & tile bridge, cutout template, white grille	C-ring & tile bridge, cutout template, white grille	C-ring & tile bridge, cutout template, white grille	C-ring & tile bridge, cutout template, white grille
Dimensions (Dia x D)	6.3" x 7.01" (160mm x 178mm)	9.13" x 8.86" (232mm x 225mm)	11.06" x 9.84" (281mm x 250mm)	11.06" x 9.84" (281mm x 250mm)	9.13" x 3.43" (232mm x 87mm)	11.06" x 4.37" (281mm x 111mm)
Cut out diameter	5.875" (149mm)	8.25" (210mm)	10.125" (257mm)	10.125" (257mm)	8.25" (210mm)	10.125" (257mm)
Certifications	UL 1480, UL 2043, NFPA90 & NFPA70; S7232	UL 1480, UL 2043, NFPA90 & NFPA70; S7232	UL 1480, UL 2043, NFPA90 & NFPA70; S7232	UL 1480, UL 2043, NFPA90 & NFPA70; S7232	UL 1480, UL 2043, NFPA90 & NFPA70; S7232	UL 1480, UL 2043, NFPA90 & NFPA70; S7232

Colors and Shapes



PENDANT SPEAKERS

Sonance Professional Series Pendant Speakers utilize a minimalistic design similar to pendant lighting to blend discreetly into the environment. Sonance's Laminated Core Transformer combined with state-of-the-art driver design delivers best-in-class fidelity and uncompromised sonic performance in 70V/100V.

THE MINIMALIST APPROACH.

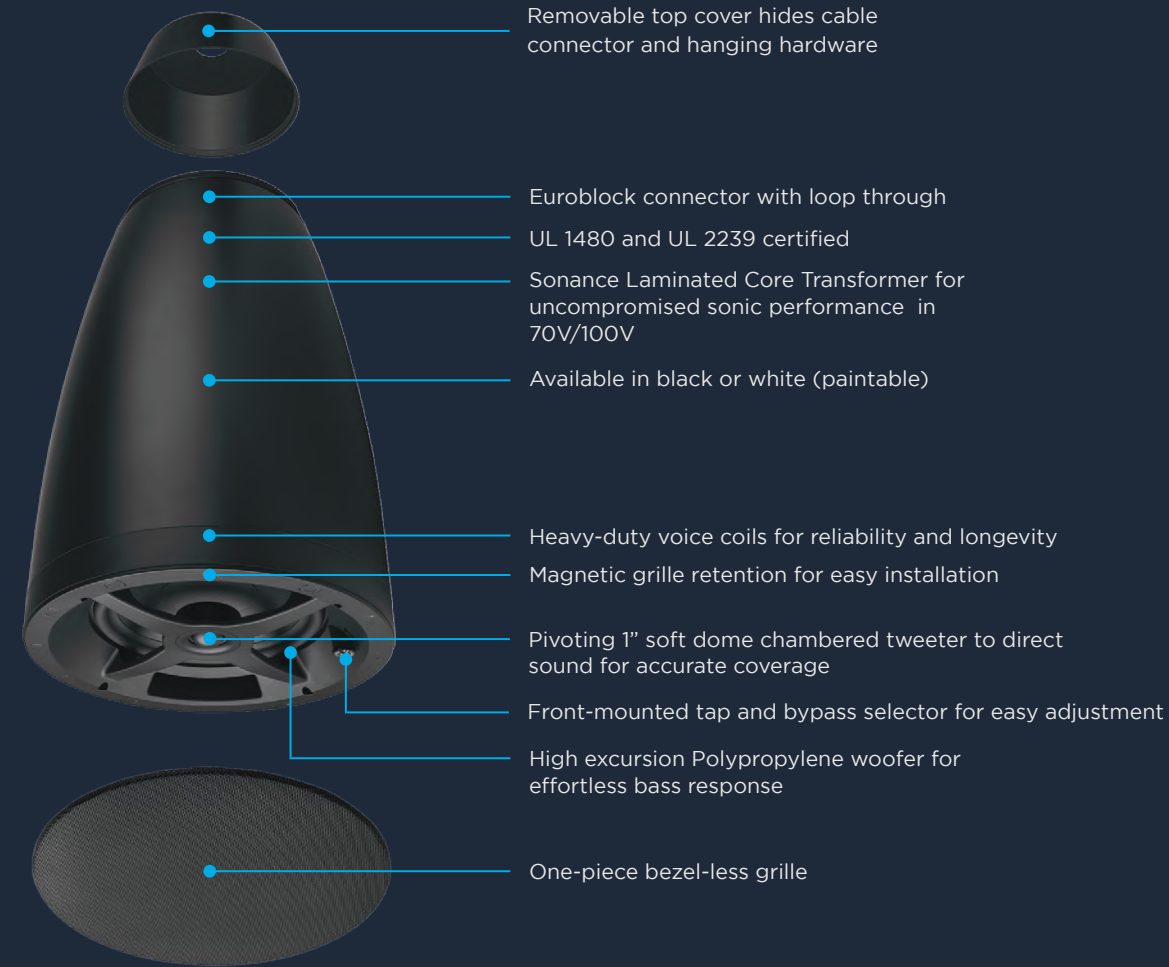

SPECIFICATIONS

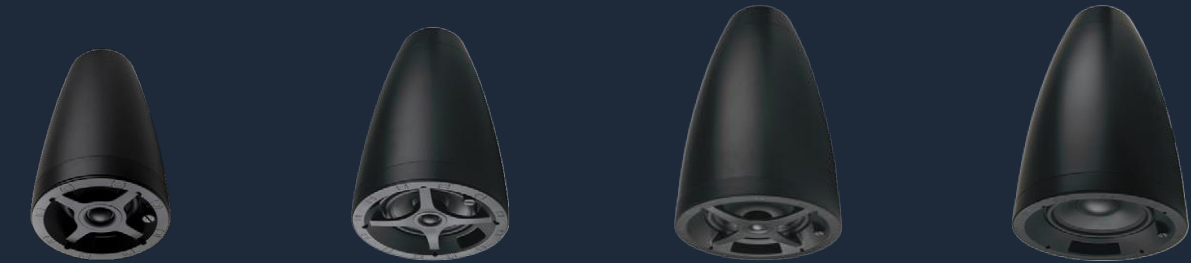

PS-P43T

PS-P63T

PS-P83T

PS-P83WT

Tweeter	1" (25mm) silk dome, pivoting	1" (25mm) silk dome, pivoting	1" (25mm) silk dome, pivoting	N/A
Woofer	4" (100mm) poly cone, rubber surround	6.5" (165mm) poly cone, rubber surround	8" (203mm) poly cone, rubber surround	8" (203mm) poly cone, rubber surround
Frequency Range +/-3dB	75Hz - 20kHz	65Hz - 20kHz	55Hz - 20kHz	50Hz - 125Hz
Power Handling RMS	60W program, 30W pink noise	150W program, 75W pink noise	200W program, 100W pink noise	300W program, 150W pink noise
Sensitivity	87dB	88dB	90dB	89dB
Transformer Taps	30W, 15W, 7.5W, (3.8W 70V), 8 Ohm	60W, 30W, 15W, (7.5W 70V), 8 Ohm	60W, 30W, 15W, (7.5W 70V), 8 Ohm	120W, 60W, 30W, (15W 70V), 8 Ohm
Impedance	8 Ohms nominal	8 Ohms nominal	8 Ohms nominal	8 Ohms nominal
Termination	Removable locking clip-in connector	Removable locking clip-in connector	Removable locking clip-in connector	Removable locking clip-in connector
Attachment	One point, top surface	One point, top surface	One point, top surface	One point, top surface
Included Accessories	2 x suspension cable, Gripple connector, zip ties	2 x suspension cable, Gripple connector, zip ties	2 x suspension cable, Gripple connector, zip ties	2 x suspension cable, Gripple connector, zip ties
Dimensions (WxD)	6.3" x 11" (160mm x 280mm)	9.13" x 15.6" (232mm x 396mm)	11.06" x 19.7" (281mm x 500mm)	11.06" x 19.7" (281mm x 500mm)
Certifications	UL 1480, UL 2239	UL 1480, UL 2239	UL 1480, UL 2239	UL 1480, UL 2239

Colors  



SURFACE MOUNT SPEAKERS

Sonance Professional Series Surface Mount Speakers feature Sonance's Fast-Mount® bracket and front cable connection to speed up the installation process and provide a minimalistic appearance. Sonance's Laminated Core Transformer combined with state-of-the-art driver design delivers best-in-class fidelity and uncompromised sonic performance in 70V/100V.

BLEND INTO THE DECOR.



- UL1480 and UL2239
- 1" soft dome chambered tweeter for clean and accurate high-end detail
- Heavy-duty voice coils for reliability and longevity
- High excursion Polypropylene woofer for effortless bass response
- Available in black or white (Paintable)
- Corrosion-resistant powder-coated aluminum grille
- Sonance Laminated Core Transformer for uncompromised sonic performance in 70V/100V
- Front-mounted connector with cover for rapid connection and to keep terminals out of elements
- Front-mounted tap and bypass select for easy adjustment
- Euroblock connector with loop through
- Sonance's FastMount bracket system with simple push and lock process for faster installation
- IPX-4 weather-resistant, high impact construction for indoor or outdoor use

SPECIFICATIONS



	PS-S43T	PS-S53T	PS-S63T	PS-S83T	PS-S83WT
Tweeter	1" (25mm) cloth dome, pivoting	1" (25mm) cloth dome, pivoting	1" (25mm) cloth dome, pivoting	1" (25mm) cloth dome, pivoting	N/A
Woofer	4" (100mm) poly cone, rubber surround	5.25" (130mm) poly cone, rubber surround	6.5" (165mm) poly cone, rubber surround	8" (203mm) poly cone, rubber surround	8" (203mm) poly cone, rubber surround
Frequency Range +/-3dB	75Hz - 20kHz	70Hz - 20kHz	65Hz - 20kHz	55Hz - 20Hz	50Hz - 150kHz
Power Handling RMS	60W program, 30W pink noise	90W program, 45W pink noise	120W program, 60W pink noise	160W program, 80W pink noise	200W program, 125W pink noise
Sensitivity	87dB	88dB	88dB	90dB	89dB
Transformer Taps	30W, 15W, 7.5W, (3.8W 70V), 8 Ohm	30W, 15W, 7.5W, (3.8W 70V), 8 Ohm	60W, 30W, 15W, (7.5W 70V), 8 Ohm	60W, 30W, 15W, (7.5W 70V), 8 Ohm	120W, 60W, 30W, (15W 70V), 8 Ohm
Impedance	8 Ohms nominal	8 Ohms nominal	8 Ohms nominal	8 Ohms nominal	8 Ohms nominal
Termination	Front locking clip-in connector	Front locking clip-in connector	Front locking clip-in connector	Front locking clip-in connector	Front locking clip-in connector
Attachment	FastMount Adjustable Bracket	FastMount Adjustable Bracket	FastMount Adjustable Bracket	FastMount Adjustable Bracket	FastMount Adjustable Bracket
Dimensions (WxHxD)	5.47" x 9.25" x 4.8" (139mm x 235mm x 122mm)	6.36" x 10.08" x 5.68" (162mm x 256mm x 144mm)	7.51" x 12.14" x 6.86" (191mm x 309mm x 174mm)	9.01" x 14.02" x 8.58" (229mm x 356mm x 218mm)	9.01" x 14.02" x 8.58" (229mm x 356mm x 218mm)
Certifications	UL 1480, IPX4	UL 1480, IPX4	UL 1480, IPX4	UL 1480, IPX4	UL 1480, IPX4





SUBWOOFERS

The PS-S210SUBT features an extremely shallow design which allows it to be used in a wide range of specialty applications such as under restaurant booths and banquettes as well as mounted onto rafters, walls or ceilings with the optional C-bracket. Featuring Sonance's Laminated Core Transformer, the PS-S210SUBT can be driven on the same amplifier channel as the other full-range loudspeakers in a system.

BIG BASS THAT'S OUT OF SIGHT.

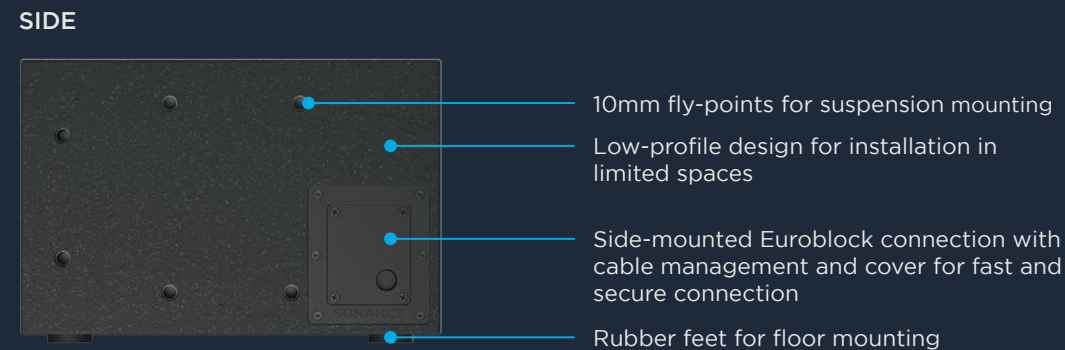
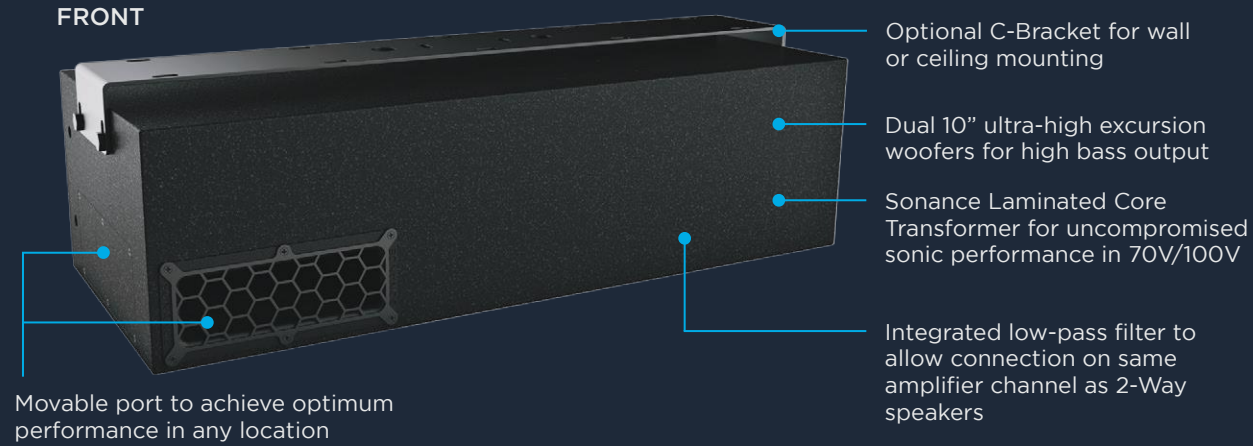

SPECIFICATIONS

PS-S210SUBT

Frequency Range +/-3dB	Power Capacity	Sensitivity	Coverage Angle
44Hz - 132kHz	500 Watts Continuous Program Power, 300 Watts Continuous Pink Noise	94 dB	180 degrees conical coverage
Rated Maximum SPL	Impedance	Transformer Taps	Crossover Point
121dB @ 1 meter (3.3 feet), 127dB peak	4 Ohms nominal	300W, 150W and (75W @70V), 8 Ohms	150Hz low pass filter, 12dB/octave
Input Connectors	Dimension (WxHxD)	Net Weight	Shipping Weight
Four pin Euroblock with loop output connections	33.00" x 8.98" x 13.78" (838mm x 228mm x 350mm)	61 lbs (27.7kg)	75.8 lbs (33.0kg)
LF Driver	Cabinet	Optional Accessories	Included Accessories
Dual 10" (254mm) Woven glass fiber cones, Butyl rubber surrounds	polyurethane coated laminated plywood	C-Bracket	(4) M10 mounting bolts, installation manual



SONANCE INVISIBLE SERIES

Sonance Invisible Series is specified exclusively in most high-profile luxury fashion boutiques around the world; chosen for its ability to deliver excellent sound quality combined with zero-visual impact. They are perfect for luxury retail, restaurants, galleries or anywhere requiring music without any visible sign of loudspeakers. Available in the IS4 C 70V/100V model.



INVISIBLE SERIES

Sonance award-winning Invisible Series Speakers are used exclusively in luxury retail boutiques around the world, including Louis Vuitton, Prada Fendi, Gucci, Tom Ford, Valentino, Tiffany's and Miu Miu. The 70V/100V or 8 Ohm design combined with best-in-class sonic performance and the most flexible installation processes makes them the perfect solution for projects requiring high quality audio combined with zero visual intrusion.

OUT OF SIGHT, NOT OUT OF MIND.

SIDE



Installs under (up to) 1/8" (3mm) of flexible material such as topping compound, venetian plaster, wood veneer or wallpaper

Shallow design of only 2" (51mm) fits in standard depth stud bay

UL1480 and UL2239 certified

170° of wide dispersion for better coverage with fewer speakers

BACK

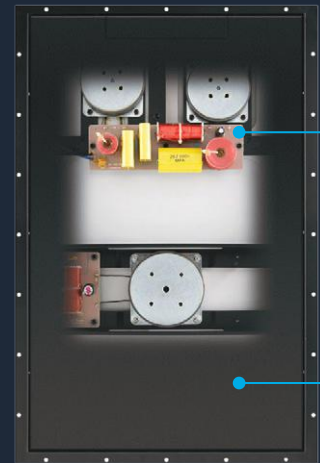

3-way driver design for full-range frequency response

Sealed acoustic enclosure to minimize sound transfer

SPECIFICATIONS

IS4 C

Tweeter	Midrange	Woofers	Frequency Range +/-3dB
4 sq. in (27 sq. cm) planar diaphragm	17 sq. in (110 sq. cm) planar diaphragm	113 sq. in (732 sq. cm) planar diaphragm	40Hz - 20kHz
Transformer Taps	Impedance	Attachment	Dimensions (WxHxD)
48W, 24W, 12W, 6W, 3W, 1.5W, (0.5W @ 70V), 8 Ohms	8 Ohms nominal	Screw connector with loop-through	16.125" x 24.125" x 3.6875" (409mm x 613mm x 94mm)
Power Handling RMS	Sensitivity	Certifications	Weight
100 Watts RMS	90dB SPL (1 Watt / 1 Meter)	UL 2043, UL 1480	28 lbs (12.7kg) each

SONANCE OUTDOOR AUDIO



Sonance Outdoor Audio solutions deliver Sonance's renowned combination of best-in-class sonic performance and aesthetics, whilst being designed and constructed to handle the harshest of conditions, including moisture, temperature extremes and salt air.



OMNI-6T

The Sonance OMNI-6T is an omnidirectional 70V/100V/8 Ohm loudspeaker, designed to deliver 360 degree coverage in applications such as resort gardens, hotel pool areas, theme parks and outdoor shopping malls. The OMNI-6T features a unique 2-way design, consisting of a high-excursion 6.5” Woofer and four x 1.25” Wide Band Drivers, providing best-in-class frequency response. Sonance’s Laminated Core Transformer delivers uncompromised fidelity in 70V/100V. The textured dark brown enclosure is designed to blend into ground cover, garden beds and foliage.

360 DEGREES OF EXCELLENCE.



- Textured brown enclosure to camouflage among foliage and ground cover
- 360 degree dispersion delivers better coverage with less speakers
- Weatherproof construction designed to handle the most extreme outdoor conditions
- Buriable design to minimize visual intrusion



- 6.5" (165mm) high excursion woofer for extended bass response
- Four x 1.25" (32mm) wide-band drivers for best-in-class treble and midrange
- Sonance Laminated Core Transformer (SLCT) for uncompromised fidelity in 70V/100V

SPECIFICATIONS



Frequency Range +/-3dB	Power Capacity	Sensitivity	Coverage Angle
60Hz - 20kHz	120 Watts Continuous Program Power, 60 Watts Continuous Pink Noise	88 dB	360 degrees horizontal, 160 degrees vertical
Rated Maximum SPL	Impedance	Transformer Taps	Crossover Point
107dB @ 1 meter (3.3 feet) average, 133dB peak	8 Ohms nominal	80W, 40W, 20W and (10W @70V), 8 Ohms	500Hz
LF Driver	Wide Band Driver	Input Connectors	Environmental
6.5" (165mm) Polypropylene Cone, Santoprene Rubber Surround	Four 1.25" (32mm) EPDM Dome, Ferrofluid Cooled	Flying Leads	Conforms to Mil Spec 810 for Humidity, IEC 529, IP-66
Included Accessories	Dimension H x Diameter	Weight	Color
Silicon Filled Wire Nuts	14.5" x 12" (368mm x 305mm)	14.60 lbs (6.62kg) each	Landscape Brown



LANDSCAPE SERIES

Sonance Landscape Series is a 70V/100V outdoor audio system, consisting of small satellite speakers and a range of in-ground or hardscape subwoofers. The system delivers unequalled sonic performance, while the scalable design makes it a perfect solution for hotel, casino and resort gardens, amusement parks, wineries, golf courses, outdoor shopping malls or any large-scale area requiring perfectly even coverage of high quality sound.

LANDSCAPES MEET SOUNDSCAPES.

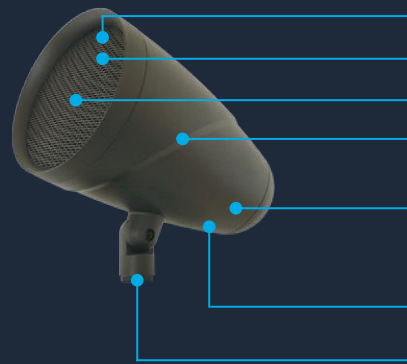

- High-dispersion grille pattern for superior coverage
- 1" Tweeter
- 4.5" (115mm) or 6.5" (165mm) mid-low driver
- Sonance Laminated Core Transformer (SLCT) for uncompromised fidelity in 70V/100V
- Weatherproof construction with triple-sealed enclosures to handle the most extreme outdoor conditions
- Various 70V/100V tap-settings, plus 8 Ohm bypass
- Versatile mounting hardware options for ground, tree, and hard surfaces

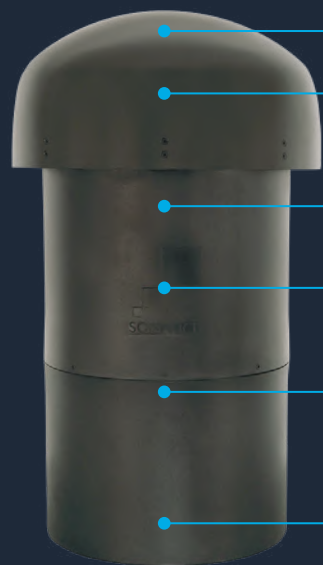

- Powdercoated metal canopy for longevity
- Weatherproof low density Polyethylene (LDPE) construction to handle the most extreme outdoor conditions
- Various 70V/100V tap-settings, plus 8 Ohm bypass
- Sonance Laminated Core Transformer (SLCT) for uncompromised fidelity in 70V/100V
- 12" (305mm) or 15" (381mm) polypropylene cone with a Santoprene™ rubber surround drivers for deep and impactful bass response
- Buriable design to minimize visual impact

SPECIFICATIONS



	LS4T SAT	LS6T SAT	LS12T SUB	LS15T SUB	HS12T SUB
Tweeter	1" (25mm) Polyurethane dome	1" (25mm) Polyurethane dome	N/A	N/A	N/A
Woofers	4 1/2" (114mm) Injection molded polypropylene cone with a Santoprene™ rubber surround	6 1/2" (165mm) Injection molded polypropylene cone with a Santoprene™ rubber surround	12" (305mm) polypropylene cone with a Santoprene™ rubber surround	15" (381mm) polypropylene cone with a Santoprene™ rubber surround	12" (305mm) polypropylene cone Santoprene™ rubber surround
Frequency Range +/-3dB	75Hz - 20kHz	55Hz - 20kHz	22Hz - 100Hz	20Hz - 100Hz	22Hz - 100Hz
Transformer Taps	40W, 20W, 10W, (5W 70V), 8 Ohms	60W, 23W, 15W, (7.5W 70V), 8 Ohms	300W, 150W, 75W, (38W 70V), 8 Ohms	300W, 150W, 75W, (38W 70V), 8 Ohms	300W, 150W, 75W, (38W 70V), 8 Ohms
Enclosure Material	High Heat ABS, non-corrosive sealed enclosure	High Heat ABS, non-corrosive sealed enclosure	Low density polyethylene (LDPE)	Low density polyethylene (LDPE)	Low density polyethylene (LDPE)
Weight	6.28 lbs (2.85 kg) each	10.75 lbs (4.88kgs) each	70.55 lbs (32.0kg) each	83.77 lbs (38.0kg) each	64.14 lbs (30.0kg) each



VP EXTREME

Sonance Visual Performance Extreme is a range of IP66 rated in-wall and in-ceiling speakers that can handle the rigors of extreme temperatures, moisture, steam, salt air, chlorine and even high winds, making them perfect for yachts, pool areas, steam rooms, saunas, and beach-side restaurants.

EXCEPTIONAL SOUND FOR EXTREME CONDITIONS.

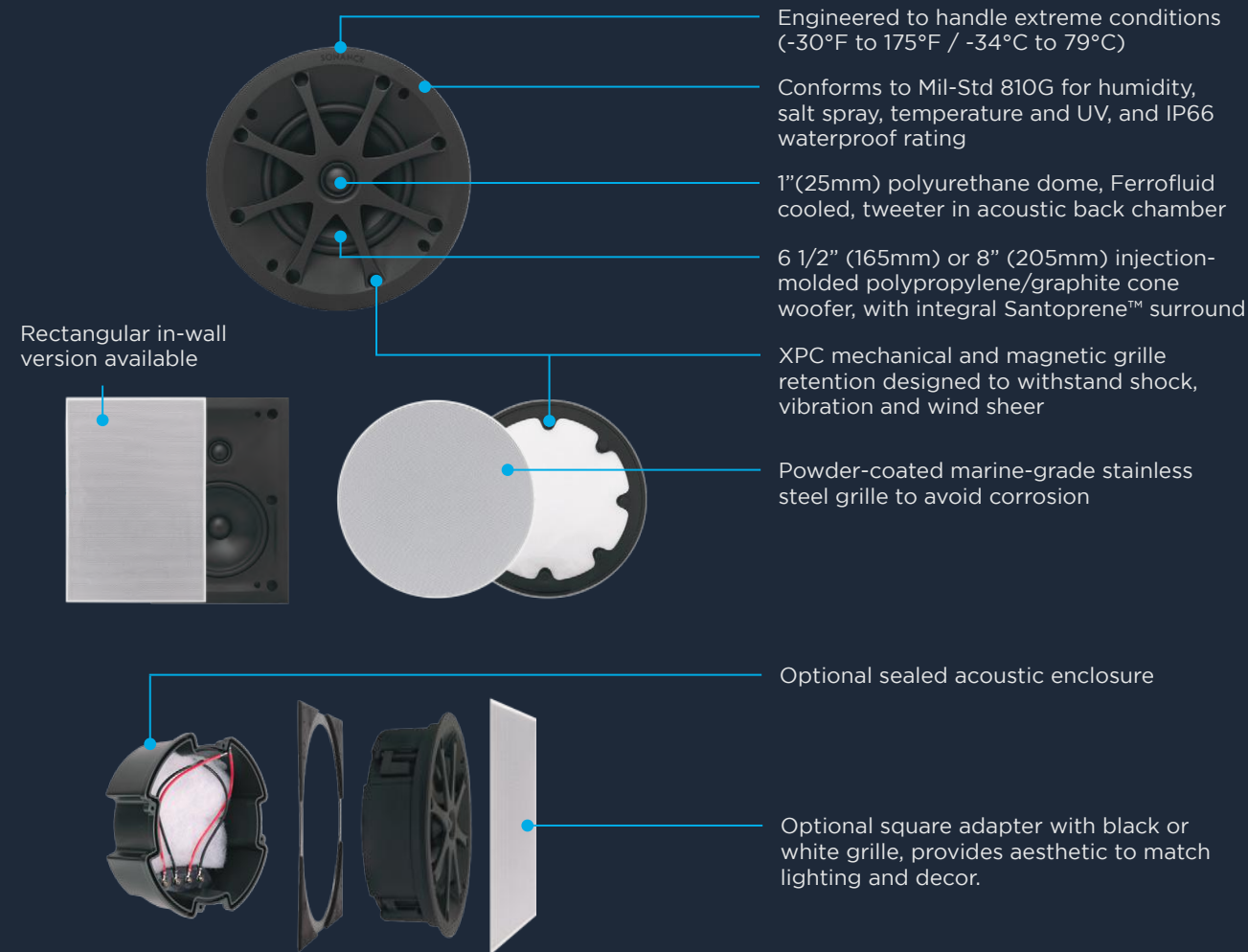

SPECIFICATIONS



	VPXT6	VPXT6R	VPXT8R
Tweeter	1" (25mm) polyurethane dome, Ferrofluid cooled, in acoustic back chamber	1" (25mm) polyurethane dome, Ferrofluid cooled, in acoustic back chamber	1" (25mm) polyurethane dome, Ferrofluid cooled, in acoustic back chamber
Woofer	6 1/2" (165mm) injection-molded polypropylene/graphite cone, with integral Santoprene™ surround	6 1/2" (165mm) Injection molded polypropylene cone with a Santoprene™ rubber surround	8" (205mm) injection-molded polypropylene/graphite cone, with integral Santoprene™ surround
Frequency Range +/-3dB	45Hz - 20kHz	45Hz - 20kHz	40Hz - 20kHz
Impedance	8 Ohms nominal	8 Ohms nominal	8 Ohms nominal
Sensitivity	89dB SPL (2.83V/1 meter)	89dB SPL (2.83V/1 meter)	90dB SPL (2.83V/1 meter)
Weight	12 lbs (5.4 kg) pair	12 lbs (5.4 kg) pair	14 lbs (6.35kg) pair

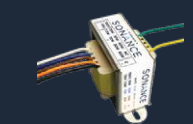
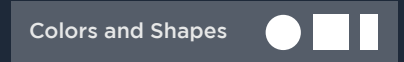

PS-60XF (Transformer)

Transformer Taps	300W, 150W, 75W, (30W @70V)
Lead Length	24" (609mm)
Mounting	2 x Mounting tabs
Dimensions	3.52" W x 1.85" D x 2.01" H (89.4mm x 47mm x 51mm)
Weight	1.19 lbs (540gm) each

The PS-60XF features the Sonance Laminated Core Transformer to deliver uncompromised sonic performance in 70V/100V installations. It enables VP Extreme (or any other Sonance high performance 8 Ohm speaker) to be used in 70V/100V commercial applications. Sold separately.

ALSO FROM SONANCE

At Sonance, we believe that audio should sound superb; that is a given. We also believe that it should blend in with the design of a space, whether it is a commercial environment, a home, indoors or outdoors; loudspeakers should be an integral part of the aesthetic, in addition to providing excellent, comfortable listening enjoyment. Our wide range of 8 Ohm products offer not only best-in-class sonic performance, but also the flexibility to perfectly match almost any application.

SOUNDBARS

Sonance Soundbars offer a wide range of solutions that fit any flat panel display from 50" up to 85". Our fixed width soundbars provide a clean aesthetic while our adjustable width soundbars provide onsite adjustability, giving you the ability to perfectly match the width of any display.



VISUAL PERFORMANCE

Sonance Visual Performance Series features an award-winning low-profile grille that is paintable to blend into the wall or ceiling. With three shapes and sizes, several performance levels, and a range of specialty application speakers, a consistent look can be achieved for any application in every space.



SUBWOOFERS

Sonance has a Subwoofer to suit every audio visual application. The range of in-wall, in-ceiling and cabinet subwoofers allows you to design a system that fits the style and needs of your environment.

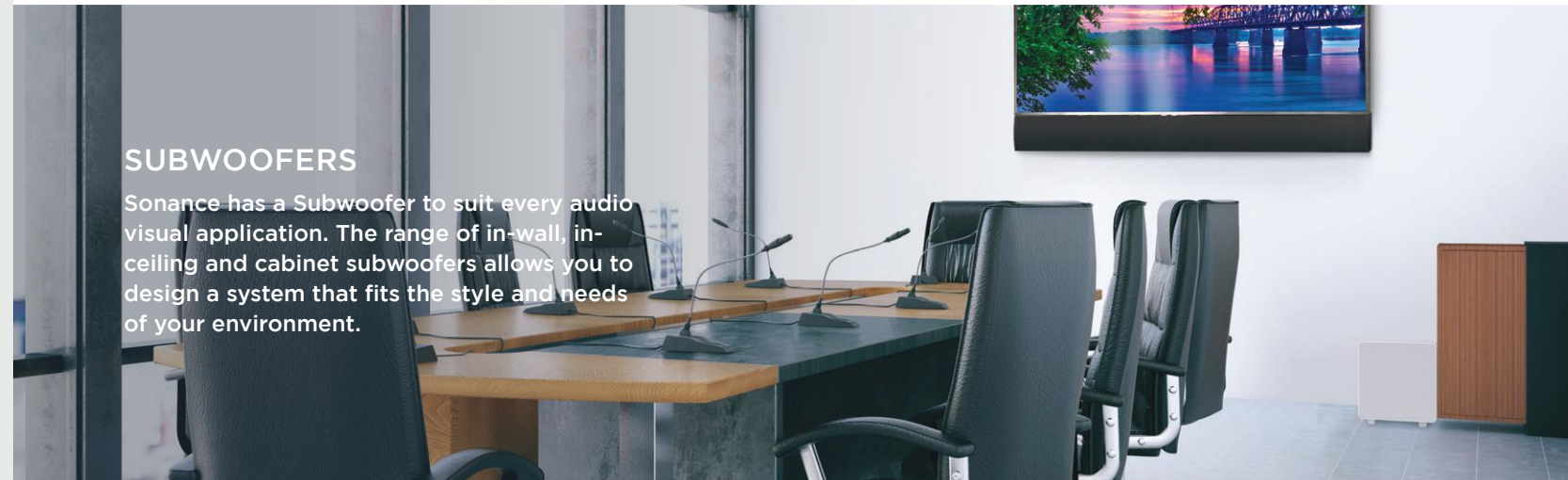

GARDEN SERIES

Sonance Garden Series borrows performance design elements from the industry-leading Sonance Landscape Series products and creates a smaller scale system ideal for outdoor areas up to 3,500 square feet (325 sq m). Sonance Garden Series is the perfect balance of performance and simplicity in an outdoor audio system.

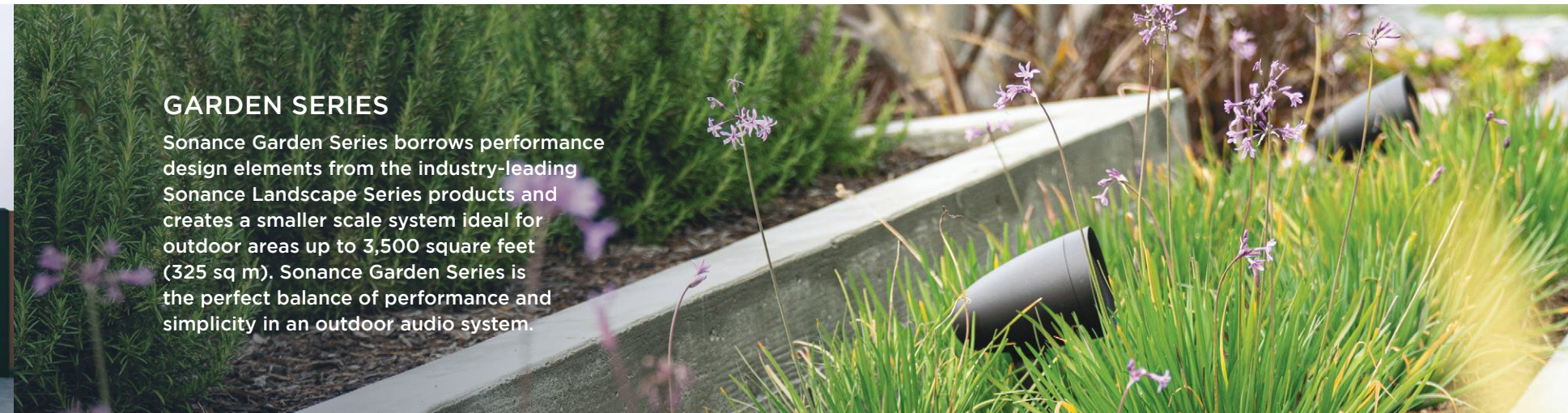

ARCHITECTURAL SERIES

Sonance Architectural Series delivers the ultimate blend of high performance and premium aesthetics. The totally flush and bezel-less grilles disappear into the surrounding ceiling surface while the state-of-the-art driver materials and cutting-edge design sets a new standard in audiophile sound quality.

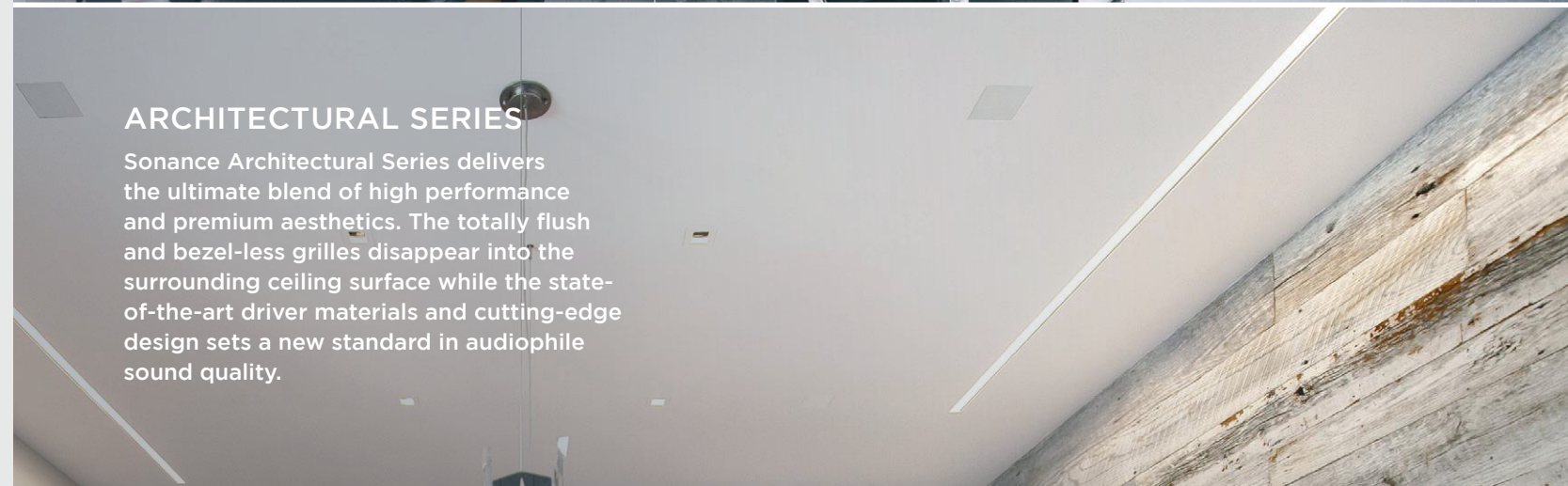

PATIO SERIES

Sonance Patio Series is an elegant outdoor all-weather audio system that blends into the surrounding landscape for an immersive music experience that emanates, seemingly, from everywhere.

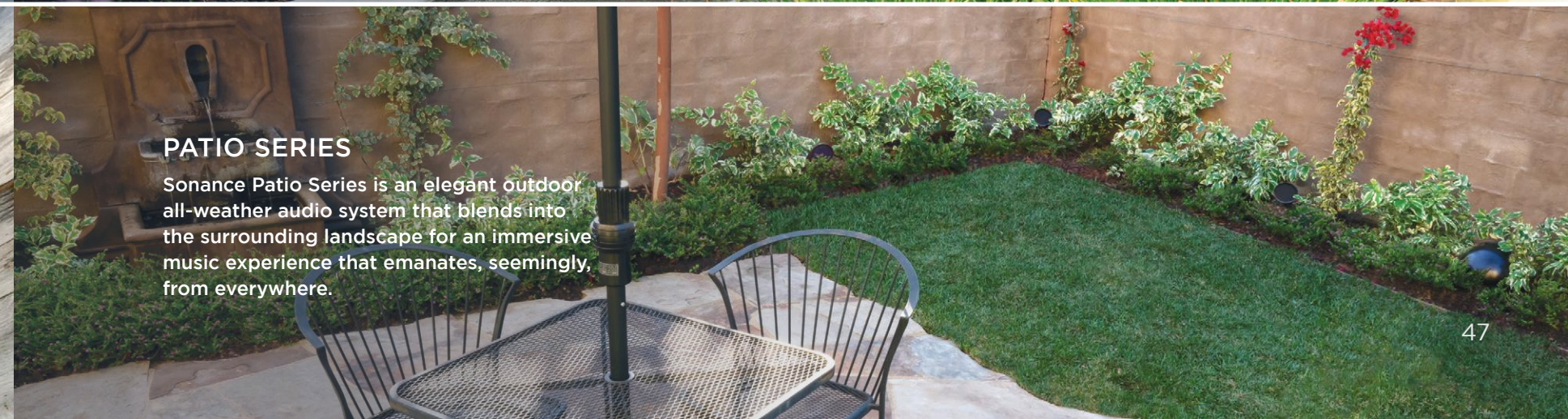



James Loudspeaker was founded in 1999 on the idea that combining a group of world-class audio engineers with a US-based manufacturing facility and a talented group of craftspeople could fundamentally change how audio could be incorporated into the most refined commercial projects.

Since inception, James Loudspeaker has amassed a catalog of over 10,000 different speaker designs and a modular construction process which allows a commercial integrator to adapt any product in the catalog to fit the design parameters or construction realities of any project.

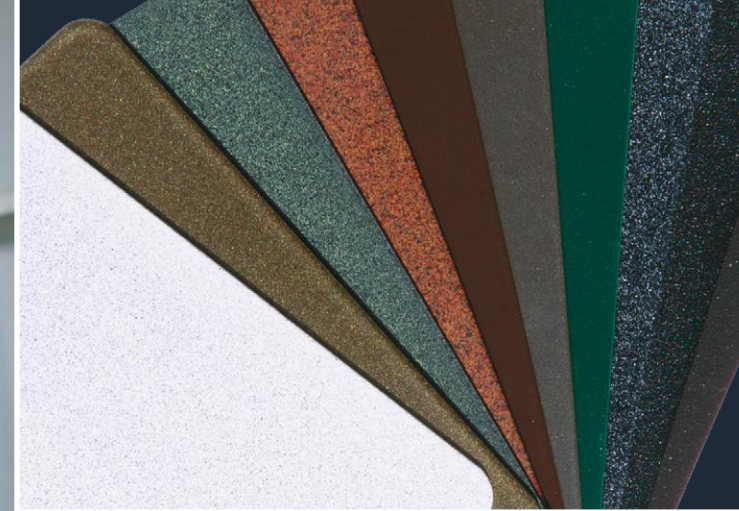

WIDE RANGE OF COLORS

At James Loudspeaker, we finish our products in a wide range of standard powder coating and paint colors. We also offer fully custom color matching to RAL or provided color samples.



CUSTOM FINISHES

We offer a unique range of custom finishes to allow our loudspeakers to disappear. This includes speaker grilles made from wood, stone or metal, and even methods like hydro-dipping which allow us to perfectly match almost any surface or pattern.



VARIOUS SHAPES AND SIZES

We can build custom loudspeaker solutions to solve your installation challenges. From changing the width of a Soundbar to match a display, to adjusting the dimensions of an enclosure to accommodate obstructions or construction-related surprises, to one-off completely custom products to integrate into a unique location - if you can dream it, we can build it.

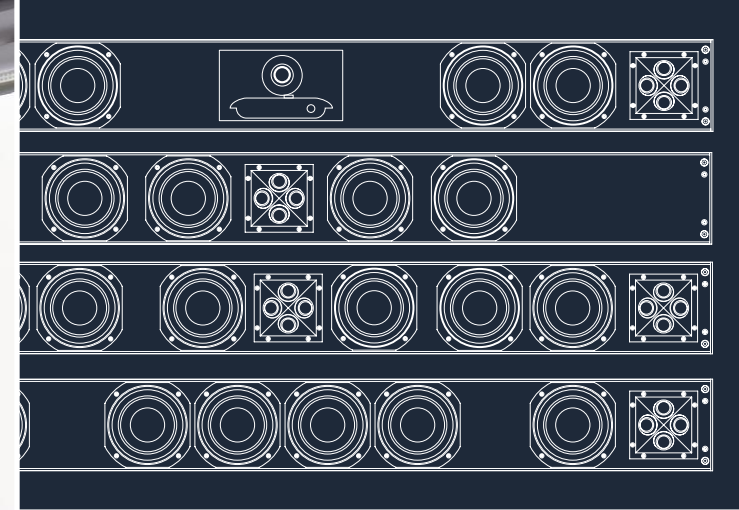

ANY CONFIGURATION

We utilize modular designs and construction processes to allow us to configure our products exactly as you need. From Soundbars in Mono, Stereo or LCR or with a space to hold a Camera, to specialized driver layouts for spaces requiring higher sound pressure levels, we can build exactly the right loudspeaker for each specific application.



MARINE-GRADE

James Loudspeaker offers a marine-grade option for most of the product line. Hardware is made from high grade galvanized 316 stainless steel which is then put through a specialized coating process. Electronic components are sealed, protecting them from moisture and corrosion. The result is outstanding reliability and longevity, even in the harshest environmental conditions.

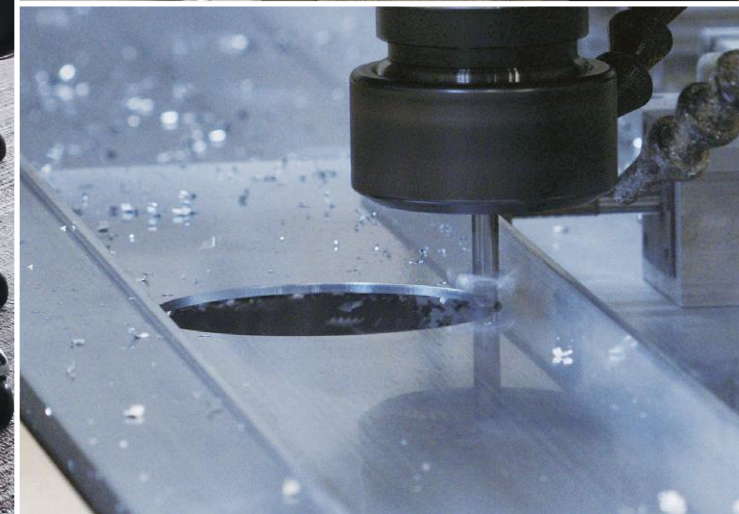

FAST TURNAROUND

James Loudspeaker products are designed and built at our factory in Minden, Nevada. Our in-house engineering and state-of-the-art factory, combined with our modular design and unique construction processes allows us to go from ideation, to specification, to manufacturing with incredibly short lead times.



WEDGE SERIES

Wedge speakers are specialized all-terrain boundary application speaker systems for integration into a 90 degree corner, such as at 2 walls or a wall and ceiling. These models are constructed entirely of aircraft grade aluminum for strength, sonic performance, and durability, and include an aluminum perforated grille to provide years of trouble free use. In addition, all Wedge speakers are marine grade making them ideal for any indoor/outdoor installation. Available in 8 Ohms or optional 70V/100V.



SMALL APERTURE SERIES

James Loudspeaker has always sought to push the envelope when it comes to better solutions through innovation, and nothing reflects that commitment like our Small Aperture® (SA) Series. SA Series features an aircraft grade aluminum enclosure with a 3-way driver design that ports through either a 3" or 4" micro-trim grille - delivering full-range performance with minimal visual intrusion. Choose from a wide range of enclosure sizes and depths, performance levels, grille finishes and even custom configuration. Available in 8 Ohms or optional 70V/100V. UL 2043 and UL 1480 certified.



LANDSCAPE SERIES

James signature All-Terrain Series features a range of 2-Way Satellite Speakers in 3", 4", 6.5", combined with direct burial Subwoofers in 8", 10", 12", 15" and 21" to deliver perfectly even coverage at almost any SPL. All our landscape speakers use aircraft grade aluminum with a heavy powder coat for ultimate protection against even the harshest outdoor conditions. Available in 8 Ohms or 70V/100V.



SOUNDBAR

Our Soundbars are completely customized for every project to ensure that each and every client gets exactly what they're looking for. Ranging from low-profile with only 1.5 inch reveal to large format bars that integrate large woofers for maximum impact, to those with a dedicated camera space, there is a bar for every application. Each bar is custom fit to the display and includes custom mounting brackets to seamlessly integrate the bar for an elegant low-impact appearance. Models available in 8 Ohm passive and powered.



POWER PIPE

James Loudspeaker PowerPipe subwoofers were created to solve an age-old problem; how to fill a space with rich, detailed bass frequencies without interfering with décor. The PowerPipe utilizes a flexible tube to move bass energy from a hidden location into the listening space through a visually unassuming grille. These subwoofers use a durable, sealed aluminum enclosure that can be concealed just about anywhere, such as above a ceiling, nestled below in a sub-floor or even stowed away in a closet.



OMNI SERIES

James Omni Series features a range of omnidirectional loudspeakers for applications where 360 degree coverage is required such as outdoor dining or shopping areas or large patios. Available in 3 sizes, with our without planter options, the Omni Series provides outstanding performance and an elegant look. Available in 4 Ohms or 70V/100V.



I PORT



At IPORT, we believe in enhancing the utility of a dedicated-use tablet at work and at home by combining design, technology, and function so that you can experience iPad® in a whole new way.

HOLD. CHARGE. PROTECT. IPAD®

WHERE YOU CAN FIND US



CORPORATE



FOOD & BEVERAGE

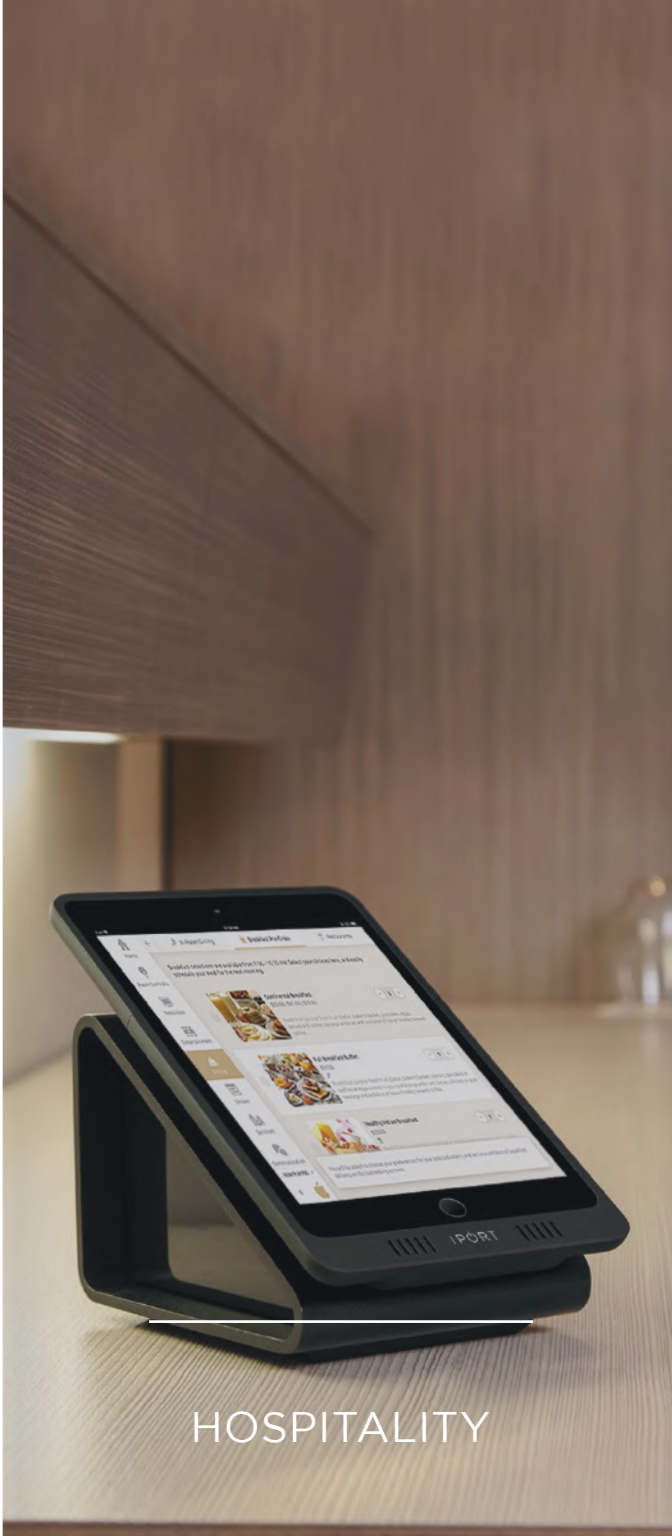

HOSPITALITY



RETAIL



HEALTHCARE



IPOINT LUXE

IPOINT LUXE is the premium wireless charging and mounting system for iPad designed for charging on table-top or on-wall. With its minimalist design and premium finishes, IPOINT LUXE blends iPad into the design of any space.

FEATURES AND BENEFITS

- Dock and charge iPad wirelessly in portrait or landscape, on a table or wall
- Precision machined aluminum components for refined and minimalist aesthetic
- Optional security feature locks case and base to any solid surface
- Power via USB power supply or standard PoE
- Available in black, white and silver

SPECIFICATIONS

CASE

Depth	mini 4 (5th gen): 0.6" (1.52 cm) - 9.7-inch: 0.7" (1.78 cm) - 10.2 10.5-inch: 0.6" (1.52 cm)
Height	mini 4 (5th gen) 9.6" (24.38 cm) - 9.7-inch: 11" (27.94 cm) - 10.2 10.5-inch: 11.5" (29.21 cm)
Weight	mini 4 (5th gen): 0.4 lbs. (0.18 kg) - 9.7-inch: 0.4 lbs. (0.18 kg) - 10.2 10.5-inch: 0.4 lbs. (0.18 kg)

BASESTATION

Depth	6.1" (15.49 cm)
Height	4.9" (12.45 cm)
Weight	1.26 lbs. (0.57 kg)

WALLSTATION

Depth	2.4" (6.1 cm)
Height	3.3" (8.38 cm)
Weight	0.18 lbs. (0.08 kg)



Colors ● ● ●





I PORT LAUNCH

I PORT LAUNCH is a wireless charging system for iPad designed to hold, charge and protect iPad on a table, wall or in a vehicle. The LAUNCH system consists of a case, and the option between a BaseStation or WallStation for mounting and charging on a table top or wall.

FEATURES AND BENEFITS

- Dock and charge iPad wirelessly in portrait or landscape, on a table, wall, or in-vehicle
- Protective case that protects iPad from drops up to 6ft (182.88cm) drop with additional Rugged Case option for even further protection
- All iPad buttons, microphones, cameras and speakers are accessible
- Contactless inductive charging
- Optional case security lock sold separately

SPECIFICATIONS

CASE

Depth	AM.2 Case mini: 0.79" (2.01 cm) - AP.5 Case 9.7 Air: 0.79" (2.01 cm) - 10.2 10.5-inch: 0.86" (2.18 cm)
Height	AM.2 Case mini: 8.66" (22.0 cm) - AP.5 Case 9.7 Air: 10.04" (25.5 cm) - 10.2 10.5-inch: 10.54" (26.77 cm)
Weight	AM.2 Case mini: 0.5 lbs. (0.23 kg) - AP.5 Case 9.7 Air: 0.73 lbs. (0.33 kg) - 10.2 10.5-inch: 0.84 lbs. (0.38 kg)

BASESTATION

Depth	6" (15.24 cm)
Height	4.5" (11.43 cm)
Weight	3.5 lbs. (1.59 kg)

WALLSTATION

Depth	2" (5.08 cm)
Height	4.9" (12.45 cm)
Weight	1.5 lbs. (0.68 kg)



Colors ● ● ●





I PORT SURFACE MOUNT

I PORT Surface Mount is the most elegant way to mount iPad on a wall or solid surface while maintaining complete access to the iPad power button, microphones and speakers. Available in black, silver or white finishes, Surface Mount ensures iPad blends into your space while keep it charged and protected.

FEATURES AND BENEFITS

- Precision machined aluminum components for refined and minimalist aesthetic
- Option to hard-wire iPad to network using Apple or 3rd party networking adapters
- Install iPad on drywall or any solid surface
- Lock iPad to wall using included security features
- Power via standard PoE

SPECIFICATIONS

BEZEL

Depth	mini 4 (5th gen): 0.5" (1.27 cm) - 9.7-inch: 0.5" (1.27 cm) - 10.2 10.5 -inch: 0.5" (1.27 cm) - 12-inch: 0.5" (1.27 cm)
Height	mini 4 (5th gen): 5.6" (14.22 cm) - 9.7-inch: 7" (17.78 cm) - 10.2 10.5 -inch: 7.3" (18.54 cm) - 12-inch: 9.6" (24.38 cm)
Weight	mini 4 (5th gen): 0.1 lbs. (0.05 kg) - 9.7-inch: 0.409 lbs. (0.19 kg) - 10.2 10.5 -inch: 0.42 lbs. (0.19 kg) - 12-inch: 1.1 lbs. (0.5 kg)

POE SPLITTER

Depth	1.97" (5.0 cm)
Height	1.46" (3.71 cm)
Weight	0.3 lbs. (0.14 kg)

POE INJECTOR

Depth	1" (2.54 cm)
Height	4" (10.16 cm)
Weight	0.5 lbs. (0.23 kg)



Colors ● ● ●



+



+



BEZEL

POE SPLITTER (OPTIONAL)

POE INJECTOR (OPTIONAL)

SONANCE
BEYOND SOUND

©2020 Sonance. All rights reserved. Sonance, James Loudspeaker and IPORT are registered trademarks.

Due to continuous product improvement, all features and specifications are subject to change without notice.
For the latest Sonance product specification information visit our website: www.sonance.com

Sonance • 991 Calle Amanecer • San Clemente, CA 92673 USA
04.08.2020 | 338064