

SONANCE MARINER SERIES

MARINER 54 OUTDOOR SPEAKER



Sonance Mariner Outdoor Speakers

Sonance is pleased to introduce a completely redesigned Mariner line of outdoor loudspeakers. Improving every aspect of the all-weather loudspeaker, the new Mariner line offers best-in-class performance in a sleek contemporary cabinet. The award winning FastMount® bracket system has been updated to match the new aesthetic of the Mariner loudspeaker to ensure the ease of installation you have come to expect from the Mariner line of speakers.

Features & Benefits

Performance

- Completely redesigned woofer, tweeter and crossover with the same materials and technology as our award-winning Visual Performance line
- A 250% increase in woofer excursion allows for significantly decreased distortion at high volumes
- .293" inches (7.44mm) increase in the diameter of the voice coils for increased output and vented pole pieces to decrease heat at voice coils
- Tweeters are chambered allowing for a lower crossover frequency, cooler operation and higher power handling
- Mariner 54 is available in a single stereo model (Mariner 54 SST)

Aesthetics

- New Black and White color for vastly improved color options
- Paintable cabinets with a clean, minimalistic design

Installation

- The award-winning Mariner outdoor speakers feature IP66 rating allowing for this loudspeaker to be used in the most challenging outdoor environments
- Precision FastMount® mounting bracket simplifies installation, provides up to 180 degrees of pivot and securely locks the speaker into place
- Grille fit has been precision engineered for ease of installation while maintaining grille retention
- Innovative front-mounted wire terminal connections protect against corrosion for a long service life
- Water impermeable drivers and sealed polypropylene enclosure ensure consistent, trouble-free performance

Specifications

SKU	WHITE - 93148 BLACK - 93149
UOM	Pair
Tweeter	1" (25mm) cloth dome, Ferrofluid cooled, in acoustic back chamber
Woofer	5.25" (130mm) textured polypropylene cone with a Santoprene surround
Frequency Response	65Hz - 20kHz ±3dB
Impedance	8 ohms nominal; 6 ohms minimum
Power Handling	5 watts minimum; 60 watts maximum
Sensitivity	87dB SPL (2.83V/1 meter)
Environmental	Conforms to Mil Spec 810 for humidity, salt spray, temperature and UV, IP-66 waterproof rating
Environment Temp	-13° - 149°F (-25°C - 65°C)
Dimensions (W x H x D)	6.36" x 10.08" x 5.68" (162mm x 256mm x 144mm)
Grille	Perforated aluminum
Shipping Weight	12 lbs. (5.5kg) pair



Dimensional Sketches Specifications

Mariner 54

Height:	10.08" (256mm)
Width:	6.36" (162mm)
Depth:	5.68" (144mm)

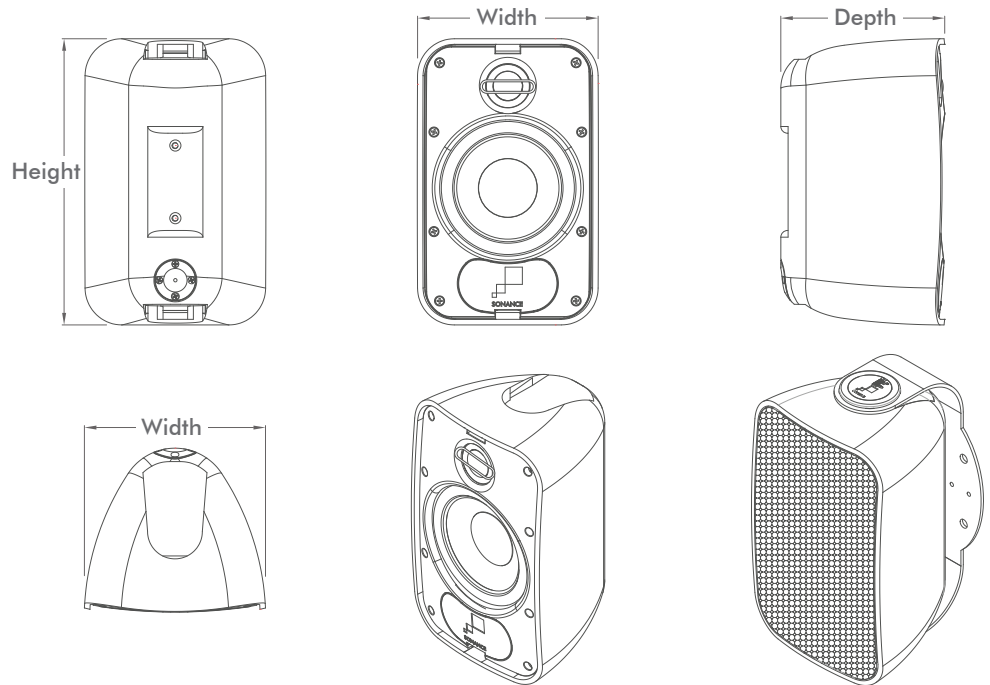

S5 Mounting Bracket

Height:	10.669" (271mm)
Width:	4.527" (115mm)
Depth	
Wall Mount:	6.181" (157mm)
Depth	
Ceiling Mount:	6.575" (167mm)

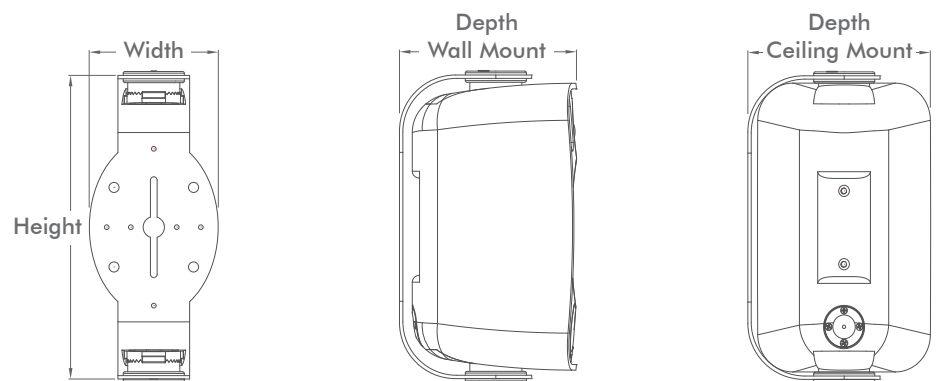

LIMITED FIVE YEAR WARRANTY - Sonance warrants to the first end-user purchaser that this Sonance-brand product (**Mariner 54**), when purchased from an authorized Sonance Dealer/Distributor, will be free from defective workmanship and materials for the life of the Product. Sonance will at its option and expense either repair the defect or replace the Product with a new or remanufactured Product or a reasonable equivalent. **Please visit our website and owner's e-Manual for complete warranty and exclusion information.**



©2017 Sonance. All rights reserved.

Sonance is a registered trademark of Dana Innovations.

Due to continuous product improvement, all features and specifications are subject to change without notice. For the latest Sonance product specification information visit our website: www.sonance.com

SONANCE • 991 Calle Amanecer • San Clemente, CA 92673 USA
(949) 492-7777 • FAX: (949) 361-5151 • Technical Support: (949) 492-7777
www.sonance.com/outdoor/rocks-mariners-extreme

05.22.17

SONANCE MARINER SERIES

MARINER 56 OUTDOOR SPEAKER



Sonance Mariner Outdoor Speakers

Sonance is pleased to introduce a completely redesigned Mariner line of outdoor loudspeakers. Improving every aspect of the all-weather loudspeaker, the new Mariner line offers best-in-class performance in a sleek contemporary cabinet. The award winning FastMount® bracket system has been updated to match the new aesthetic of the Mariner loudspeaker to ensure the ease of installation you have come to expect from the Mariner line of speakers.

Features & Benefits

Performance

- Completely redesigned woofer, tweeter and crossover with the same materials and technology as our award-winning Visual Performance line
- A 250% increase in woofer excursion allows for significantly decreased distortion at high volumes
- .293" inches (7.44mm) increase in the diameter of the voice coils for increased output and vented pole pieces to decrease heat at voice coils
- Tweeters are chambered allowing for a lower crossover frequency, cooler operation and higher power handling

Aesthetics

- New Black and White color for vastly improved color options
- Paintable cabinets with a clean, minimalistic design

Installation

- The award-winning Mariner outdoor speakers feature IP66 rating allowing for this loudspeaker to be used in the most challenging outdoor environments
- Precision FastMount® mounting bracket simplifies installation, provides up to 180 degrees of pivot and securely locks the speaker into place
- Grille fit has been precision engineered for ease of installation while maintaining grille retention
- Innovative front-mounted wire terminal connections protect against corrosion for a long service life
- Water impermeable drivers and sealed polypropylene enclosure ensure consistent, trouble-free performance

Specifications

SKU	WHITE - 93150 BLACK - 93151
UOM	Pair
Tweeter	1" (25mm) powder-coated aluminum dome, Ferrofluid cooled, in acoustic back chamber
Woofer	5.25" (130mm) Kevlar/Nomex laminated cone with a Santoprene surround
Frequency Response	60Hz - 20kHz ±3dB
Impedance	8 ohms nominal; 6 ohms minimum
Power Handling	5 watts minimum; 70 watts maximum
Sensitivity	88dB SPL (2.83V/1 meter)
Environmental	Conforms to Mil Spec 810 for humidity, salt spray, temperature and UV, IP-66 waterproof rating
Environment Temp	-13° - 149°F (-25°C - 65°C)
Dimensions (W x H x D)	6.36" x 10.08" x 5.68" (162mm x 256mm x 144mm)
Grille	Perforated aluminum
Shipping Weight	13 lbs. (6kg) pair



Dimensional Sketches Specifications

Mariner 56

Height:	10.08" (256mm)
Width:	6.36" (162mm)
Depth:	5.68" (144mm)

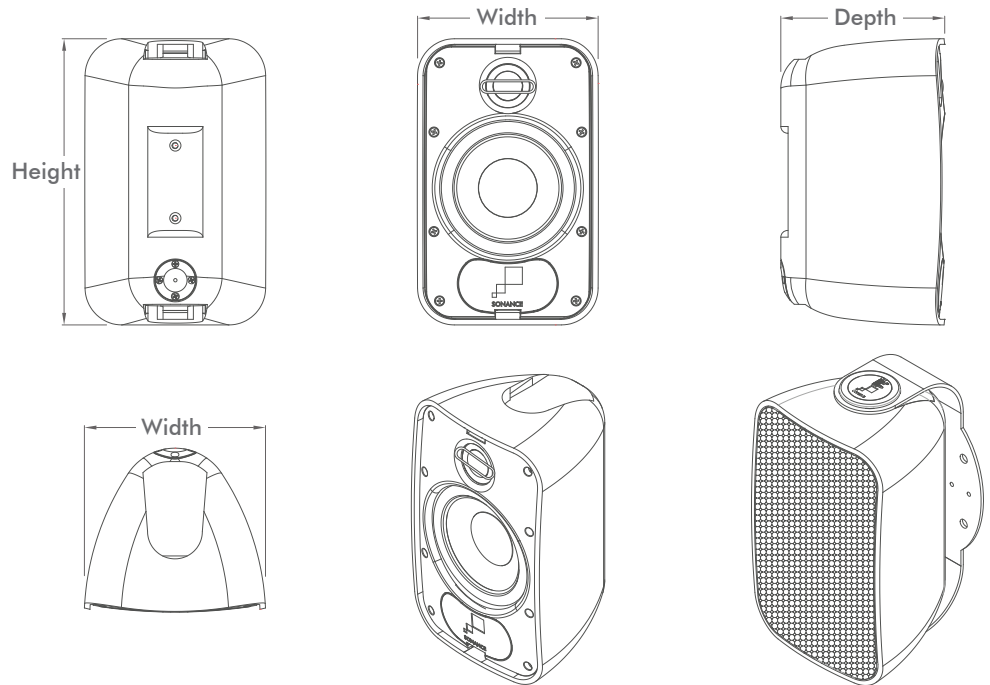

S5 Mounting Bracket

Height:	10.669" (271mm)
Width:	4.527" (115mm)
Depth	
Wall Mount:	6.181" (157mm)
Depth	
Ceiling Mount:	6.575" (167mm)

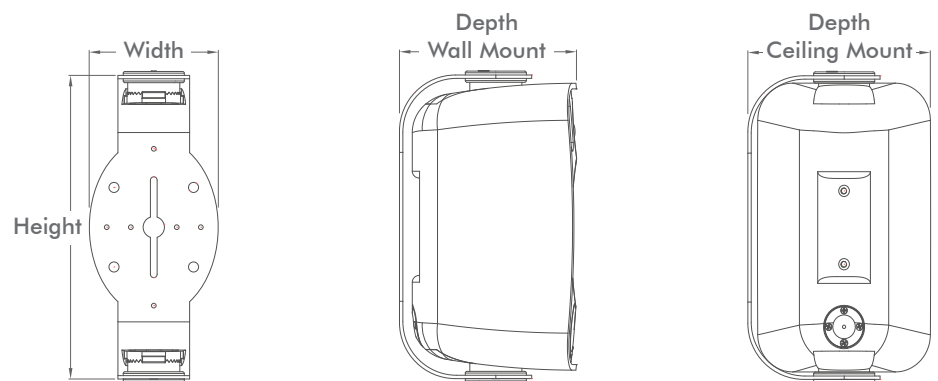

LIMITED FIVE YEAR WARRANTY - Sonance warrants to the first end-user purchaser that this Sonance-brand product (**Mariner 56**), when purchased from an authorized Sonance Dealer/Distributor, will be free from defective workmanship and materials for the life of the Product. Sonance will at its option and expense either repair the defect or replace the Product with a new or remanufactured Product or a reasonable equivalent. **Please visit our website and owner's e-Manual for complete warranty and exclusion information.**



©2017 Sonance. All rights reserved.

Sonance is a registered trademark of Dana Innovations.

Due to continuous product improvement, all features and specifications are subject to change without notice. For the latest Sonance product specification information visit our website: www.sonance.com

SONANCE • 991 Calle Amanecer • San Clemente, CA 92673 USA
(949) 492-7777 • FAX: (949) 361-5151 • Technical Support: (949) 492-7777
www.sonance.com/outdoor/rocks-mariners-extreme

05.22.17

SONANCE MARINER SERIES

MARINER 54 SST OUTDOOR SPEAKER



Sonance Mariner Outdoor Speakers

Sonance is pleased to introduce a completely redesigned Mariner line of outdoor loudspeakers. Improving every aspect of the all-weather loudspeaker, the new Mariner line offers best-in-class performance in a sleek contemporary cabinet. The award winning FastMount® bracket system has been updated to match the new aesthetic of the Mariner loudspeaker to ensure the ease of installation you have come to expect from the Mariner line of speakers.

Features & Benefits

Performance

- Completely redesigned woofer, tweeter and crossover with the same materials and technology as our award-winning Visual Performance line
- A 250% increase in woofer excursion allows for significantly decreased distortion at high volumes
- .293" inches (7.44mm) increase in the diameter of the voice coils for increased output and vented pole pieces to decrease heat at voice coils
- Tweeters are chambered allowing for a lower crossover frequency, cooler operation and higher power handling

Aesthetics

- New Black and White color for vastly improved color options
- Paintable cabinets with a clean, minimalistic design

Installation

- The award-winning Mariner outdoor speakers feature IP66 rating allowing for this loudspeaker to be used in the most challenging outdoor environments
- Precision FastMount® mounting bracket simplifies installation, provides up to 180 degrees of pivot and securely locks the speaker into place
- Grille fit has been precision engineered for ease of installation while maintaining grille retention
- Innovative front-mounted wire terminal connections protect against corrosion for a long service life
- Water impermeable drivers and sealed polypropylene enclosure ensure consistent, trouble-free performance

Specifications

SKU	WHITE - 93158 BLACK - 93159
UOM	Each
Tweeter	Two 1" (25mm) cloth dome, Ferrofluid cooled, in acoustic back chamber
Woofer	5.25" (130mm) textured polypropylene cone with a Santoprene surround, dual voice coil
Frequency Response	65Hz - 20kHz ±3dB
Impedance	8 ohms nominal; 6 ohms minimum
Power Handling	5 watts minimum; 60 watts maximum
Sensitivity	87dB SPL (2.83V/1 meter)
Environmental	Conforms to Mil Spec 810 for humidity, salt spray, temperature and UV, IP-66 waterproof rating
Environment Temp	-13° - 149°F (-25°C - 65°C)
Dimensions (W x H x D)	6.36" x 10.08" x 5.68" (162mm x 256mm x 144mm)
Grille	Perforated aluminum
Shipping Weight	6 lbs. (2.8kg) each



Dimensional Sketches Specifications

Mariner 54 SST

Height:	10.08" (256mm)
Width:	6.36" (162mm)
Depth:	5.68" (144mm)

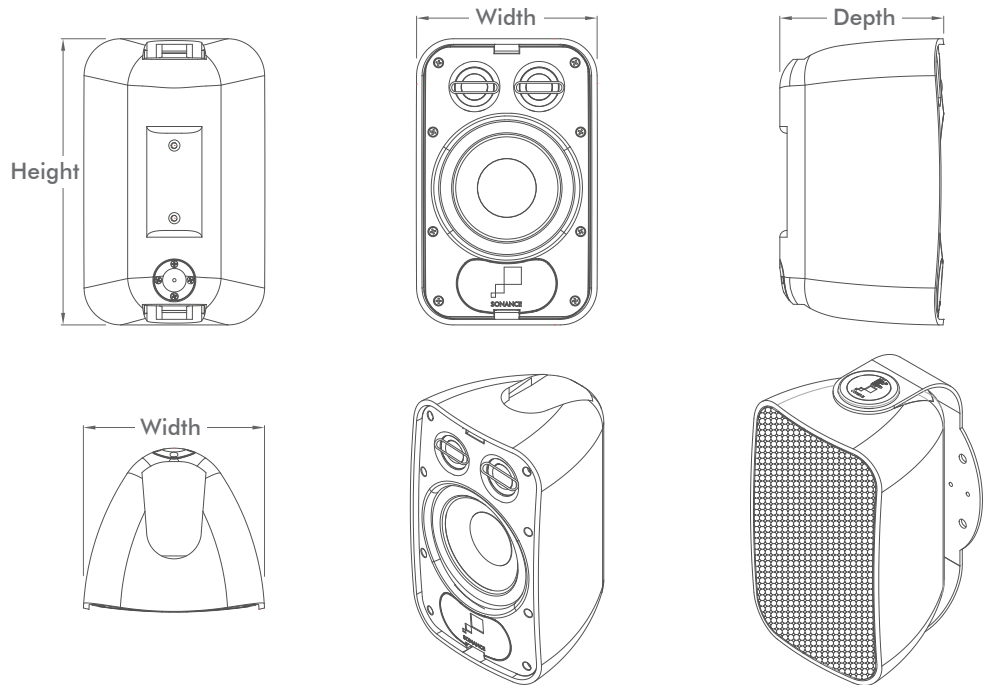

S5 Mounting Bracket

Height:	10.669" (271mm)
Width:	4.527" (115mm)
Depth	
Wall Mount:	6.181" (157mm)
Depth	
Ceiling Mount:	6.575" (167mm)

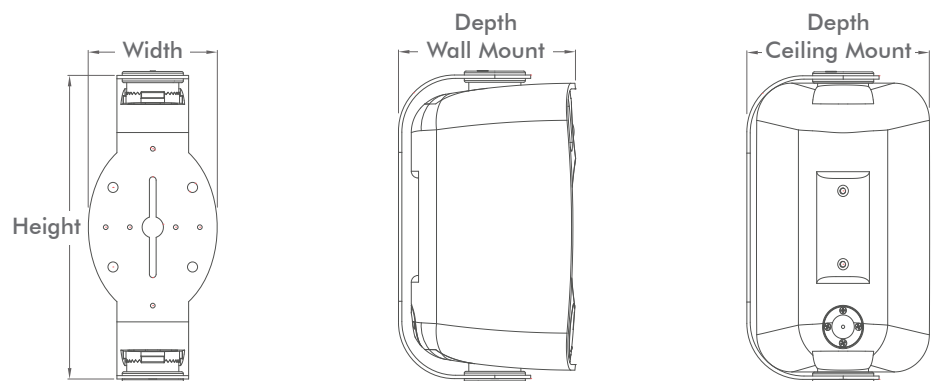

LIMITED FIVE YEAR WARRANTY - Sonance warrants to the first end-user purchaser that this Sonance-brand product (**Mariner 54 SST**), when purchased from an authorized Sonance Dealer/Distributor, will be free from defective workmanship and materials for the life of the Product. Sonance will at its option and expense either repair the defect or replace the Product with a new or remanufactured Product or a reasonable equivalent. **Please visit our website and owner's e-Manual for complete warranty and exclusion information.**



©2017 Sonance. All rights reserved.
Sonance is a registered trademark of Dana Innovations.

Due to continuous product improvement, all features and specifications are subject to change without notice.
For the latest Sonance product specification information visit our website: www.sonance.com

SONANCE • 991 Calle Amanecer • San Clemente, CA 92673 USA
(949) 492-7777 • FAX: (949) 361-5151 • Technical Support: (949) 492-7777
www.sonance.com/outdoor/rocks-mariners-extreme

05.22.17

SONANCE MARINER SERIES

MARINER 64 OUTDOOR SPEAKER



Sonance Mariner Outdoor Speakers

Sonance is pleased to introduce a completely redesigned Mariner line of outdoor loudspeakers. Improving every aspect of the all-weather loudspeaker, the new Mariner line offers best-in-class performance in a sleek contemporary cabinet. The award winning FastMount® bracket system has been updated to match the new aesthetic of the Mariner loudspeaker to ensure the ease of installation you have come to expect from the Mariner line of speakers.

Features & Benefits

Performance

- Completely redesigned woofer, tweeter and crossover with the same materials and technology as our award-winning Visual Performance line
- A 250% increase in woofer excursion allows for significantly decreased distortion at high volumes
- .293" inches (7.44mm) increase in the diameter of the voice coils for increased output and vented pole pieces to decrease heat at voice coils
- Tweeters are chambered allowing for a lower crossover frequency, cooler operation and higher power handling
- Mariner 64 is available in a single stereo model (Mariner 64 SST)

Aesthetics

- New Black and White color for vastly improved color options
- Paintable cabinets with a clean, minimalistic design

Installation

- The award-winning Mariner outdoor speakers feature IP66 rating allowing for this loudspeaker to be used in the most challenging outdoor environments
- Precision FastMount® mounting bracket simplifies installation, provides up to 180 degrees of pivot and securely locks the speaker into place
- Grille fit has been precision engineered for ease of installation while maintaining grille retention
- Innovative front-mounted wire terminal connections protect against corrosion for a long service life
- Water impermeable drivers and sealed polypropylene enclosure ensure consistent, trouble-free performance

Specifications

SKU	WHITE - 93152 BLACK - 93153
UOM	Pair
Tweeter	1" (25mm) cloth dome, Ferrofluid cooled, in acoustic back chamber
Woofer	6.5" (165mm) textured polypropylene cone with a Santoprene surround
Frequency Response	55Hz - 20kHz ±3dB
Impedance	8 ohms nominal; 6 ohms minimum
Power Handling	5 watts minimum; 80 watts maximum
Sensitivity	89dB SPL (2.83V/1 meter)
Environmental	Conforms to Mil Spec 810 for humidity, salt spray, temperature and UV, IP-66 waterproof rating
Environment Temp	-13° - 149°F (-25°C - 65°C)
Dimensions (W x H x D)	7.51" x 12.14" x 6.86" (191mm x 308mm x 174mm)
Grille	Perforated aluminum
Shipping Weight	14 lbs. (6.4kg) pair



Dimensional Sketches Specifications

Mariner 64

Height:	12.14" (308mm)
Width:	7.51" (191mm)
Depth:	6.86" (174mm)

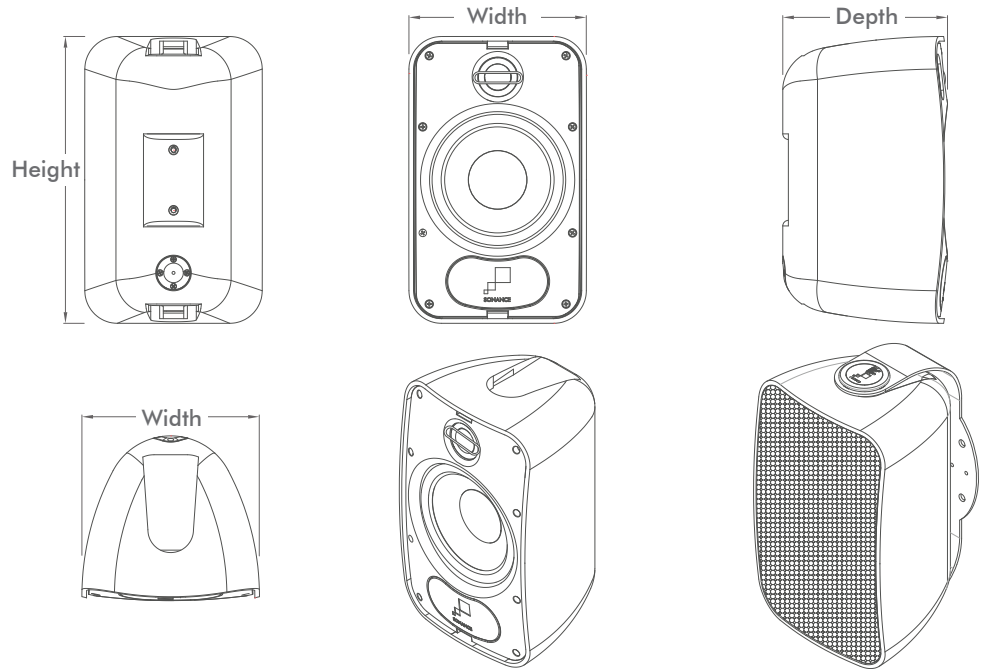

S6 Mounting Bracket

Height:	12.657" (322mm)
Width:	4.527" (115mm)
Depth	
Wall Mount:	7.48" (190mm)
Depth	
Ceiling Mount:	8.268" (210mm)

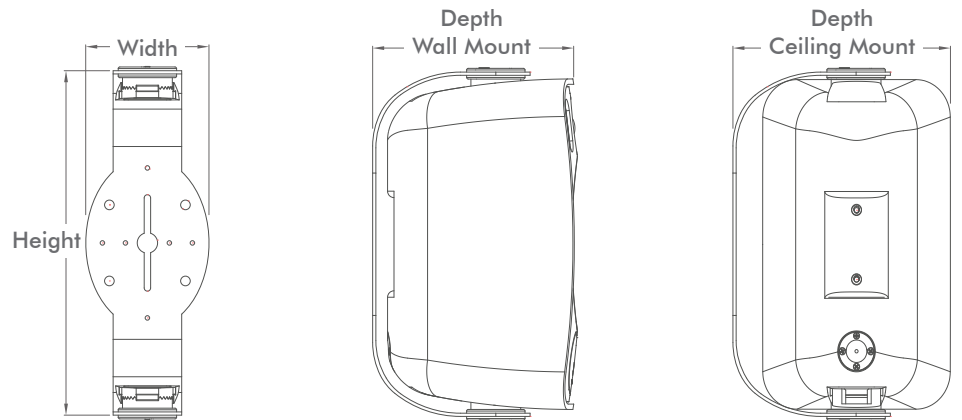

LIMITED FIVE YEAR WARRANTY - Sonance warrants to the first end-user purchaser that this Sonance-brand product (**Mariner 64**), when purchased from an authorized Sonance Dealer/Distributor, will be free from defective workmanship and materials for the life of the Product. Sonance will at its option and expense either repair the defect or replace the Product with a new or remanufactured Product or a reasonable equivalent. **Please visit our website and owner's e-Manual for complete warranty and exclusion information.**



©2017 Sonance. All rights reserved.
Sonance is a registered trademark of Dana Innovations.

Due to continuous product improvement, all features and specifications are subject to change without notice.
For the latest Sonance product specification information visit our website: www.sonance.com

SONANCE • 991 Calle Amanecer • San Clemente, CA 92673 USA
(949) 492-7777 • FAX: (949) 361-5151 • Technical Support: (949) 492-7777
www.sonance.com/outdoor/rocks-mariners-extreme

05.22.17

SONANCE MARINER SERIES

MARINER 66 OUTDOOR SPEAKER



Sonance Mariner Outdoor Speakers

Sonance is pleased to introduce a completely redesigned Mariner line of outdoor loudspeakers. Improving every aspect of the all-weather loudspeaker, the new Mariner line offers best-in-class performance in a sleek contemporary cabinet. The award winning FastMount® bracket system has been updated to match the new aesthetic of the Mariner loudspeaker to ensure the ease of installation you have come to expect from the Mariner line of speakers.

Features & Benefits

Performance

- Completely redesigned woofer, tweeter and crossover with the same materials and technology as our award-winning Visual Performance line
- A 250% increase in woofer excursion allows for significantly decreased distortion at high volumes
- .293" inches (7.44mm) increase in the diameter of the voice coils for increased output and vented pole pieces to decrease heat at voice coils
- Tweeters are chambered allowing for a lower crossover frequency, cooler operation and higher power handling

Aesthetics

- New Black and White color for vastly improved color options
- Paintable cabinets with a clean, minimalistic design

Installation

- The award-winning Mariner outdoor speakers feature IP66 rating allowing for this loudspeaker to be used in the most challenging outdoor environments
- Precision FastMount® mounting bracket simplifies installation, provides up to 180 degrees of pivot and securely locks the speaker into place
- Grille fit has been precision engineered for ease of installation while maintaining grille retention
- Innovative front-mounted wire terminal connections protect against corrosion for a long service life
- Water impermeable drivers and sealed polypropylene enclosure ensure consistent, trouble-free performance

Specifications

SKU	WHITE - 93154 BLACK - 93155
UOM	Pair
Tweeter	1" (25mm) powder-coated aluminum dome, Ferrofluid cooled, in acoustic back chamber
Woofer	6.5" (165mm) Kevlar/Nomex laminated cone with a Santoprene surround
Frequency Response	50Hz - 20kHz ±3dB
Impedance	8 ohms nominal; 6 ohms minimum
Power Handling	5 watts minimum; 100 watts maximum
Sensitivity	90dB SPL (2.83V/1 meter)
Environmental	Conforms to Mil Spec 810 for humidity, salt spray, temperature and UV, IP-66 waterproof rating
Environment Temp	-13° - 149°F (-25°C - 65°C)
Dimensions (W x H x D)	7.51" x 12.14" x 6.86" (191mm x 308mm x 174mm)
Grille	Perforated aluminum
Shipping Weight	17 lbs. (7.7kg) pair



Dimensional Sketches Specifications

Mariner 66

Height:	12.14" (308mm)
Width:	7.51" (191mm)
Depth:	6.86" (174mm)

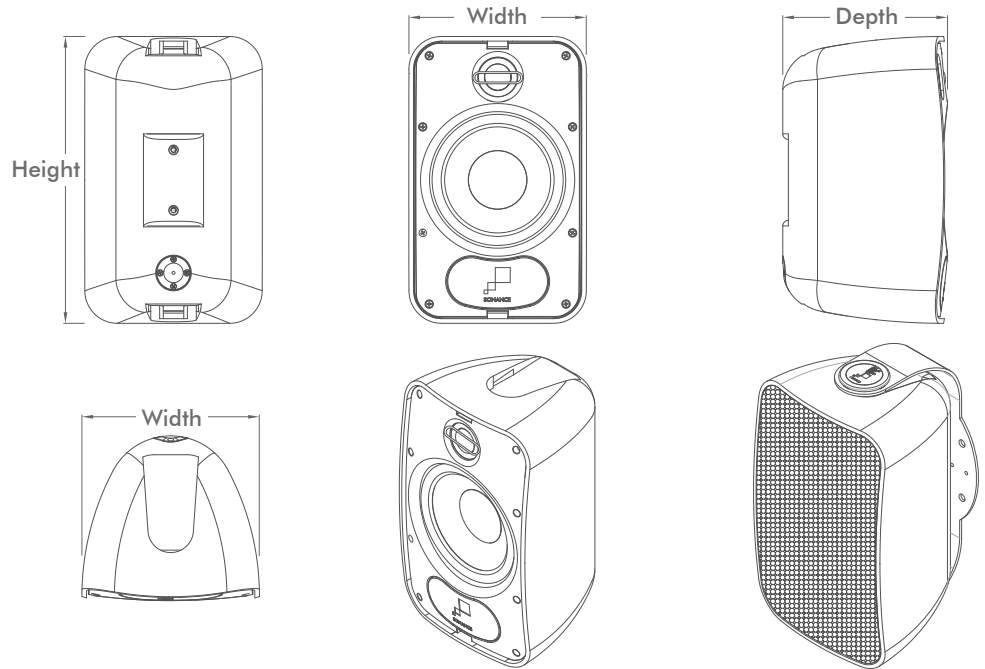

S6 Mounting Bracket

Height:	12.657" (322mm)
Width:	4.527" (115mm)
Depth Wall Mount:	7.48" (190mm)
Depth Ceiling Mount:	8.268" (210mm)

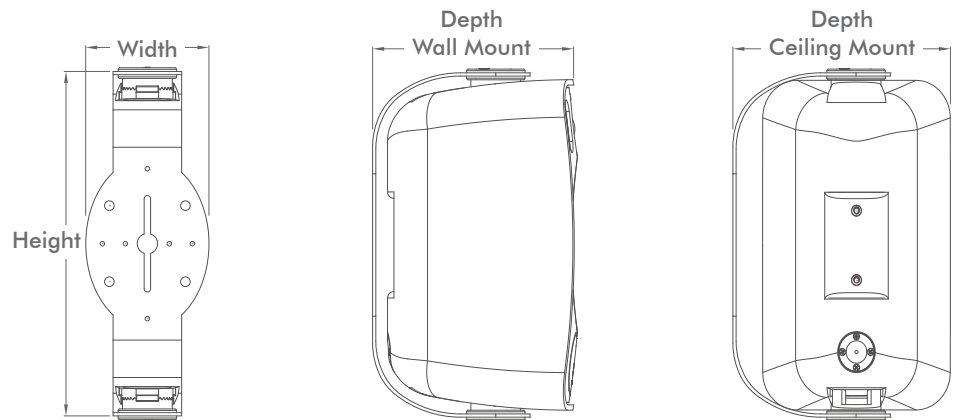

LIMITED FIVE YEAR WARRANTY - Sonance warrants to the first end-user purchaser that this Sonance-brand product (**Mariner 66**), when purchased from an authorized Sonance Dealer/Distributor, will be free from defective workmanship and materials for the life of the Product. Sonance will at its option and expense either repair the defect or replace the Product with a new or remanufactured Product or a reasonable equivalent. **Please visit our website and owner's e-Manual for complete warranty and exclusion information.**



©2017 Sonance. All rights reserved.

Sonance is a registered trademark of Dana Innovations.

Due to continuous product improvement, all features and specifications are subject to change without notice. For the latest Sonance product specification information visit our website: www.sonance.com

SONANCE • 991 Calle Amanecer • San Clemente, CA 92673 USA
(949) 492-7777 • FAX: (949) 361-5151 • Technical Support: (949) 492-7777
www.sonance.com/outdoor/rocks-mariners-extreme

05.22.17

SONANCE MARINER SERIES

MARINER 64 SST OUTDOOR SPEAKER



Sonance Mariner Outdoor Speakers

Sonance is pleased to introduce a completely redesigned Mariner line of outdoor loudspeakers. Improving every aspect of the all-weather loudspeaker, the new Mariner line offers best-in-class performance in a sleek contemporary cabinet. The award winning FastMount® bracket system has been updated to match the new aesthetic of the Mariner loudspeaker to ensure the ease of installation you have come to expect from the Mariner line of speakers.

Features & Benefits

Performance

- Completely redesigned woofer, tweeter and crossover with the same materials and technology as our award-winning Visual Performance line
- A 250% increase in woofer excursion allows for significantly decreased distortion at high volumes
- .293" inches (7.44mm) increase in the diameter of the voice coils for increased output and vented pole pieces to decrease heat at voice coils
- Tweeters are chambered allowing for a lower crossover frequency, cooler operation and higher power handling

Aesthetics

- New Black and White color for vastly improved color options
- Paintable cabinets with a clean, minimalistic design

Installation

- The award-winning Mariner outdoor speakers feature IP66 rating allowing for this loudspeaker to be used in the most challenging outdoor environments
- Precision FastMount® mounting bracket simplifies installation, provides up to 180 degrees of pivot and securely locks the speaker into place
- Grille fit has been precision engineered for ease of installation while maintaining grille retention
- Innovative front-mounted wire terminal connections protect against corrosion for a long service life
- Water impermeable drivers and sealed polypropylene enclosure ensure consistent, trouble-free performance

Specifications

SKU	WHITE - 93160 BLACK - 93161
UOM	Each
Tweeter	Two 1" (25mm) cloth dome, Ferrofluid cooled in acoustic back chamber
Woofer	6.5" (165mm) textured polypropylene cone with a Santoprene surround, dual voice coil
Frequency Response	55Hz - 20kHz ±3dB
Impedance	8 ohms nominal; 6 ohms minimum
Power Handling	5 watts minimum; 80 watts maximum
Sensitivity	89dB SPL (2.83V/1 meter)
Environmental	Conforms to Mil Spec 810 for humidity, salt spray, temperature and UV, IP-66 waterproof rating
Environment Temp	-13° - 149°F (-25°C - 65°C)
Dimensions (W x H x D)	7.51" x 12.14" x 6.86" (191mm x 308mm x 174mm)
Grille	Perforated aluminum
Shipping Weight	7 lbs. (3.2kg) each



Dimensional Sketches Specifications

Mariner 64 SST

Height:	12.14" (308mm)
Width:	7.51" (191mm)
Depth:	6.86" (174mm)

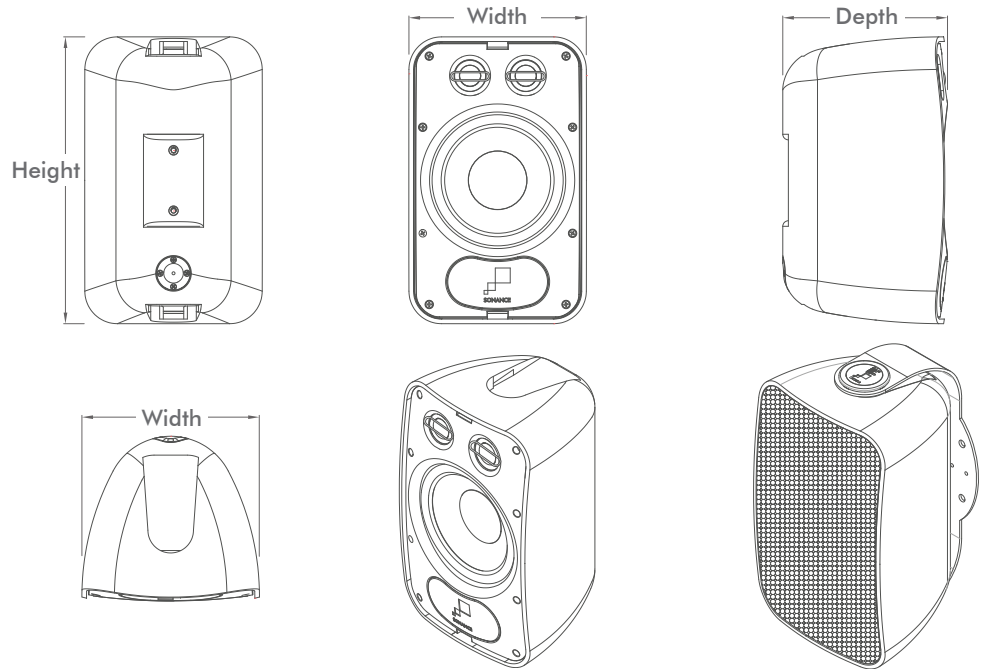

S6 Mounting Bracket

Height:	12.657" (322mm)
Width:	4.527" (115mm)
Depth Wall Mount:	7.48" (190mm)
Depth Ceiling Mount:	8.268" (210mm)

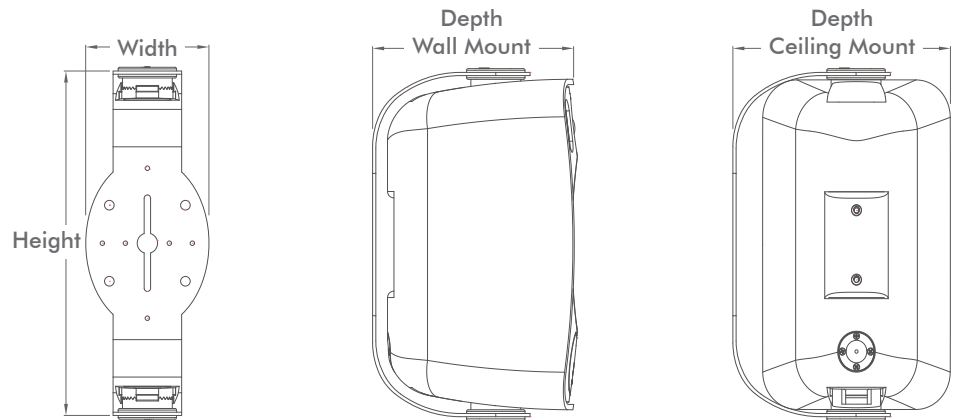

LIMITED FIVE YEAR WARRANTY - Sonance warrants to the first end-user purchaser that this Sonance-brand product (**Mariner 64 SST**), when purchased from an authorized Sonance Dealer/Distributor, will be free from defective workmanship and materials for the life of the Product. Sonance will at its option and expense either repair the defect or replace the Product with a new or remanufactured Product or a reasonable equivalent. **Please visit our website and owner's e-Manual for complete warranty and exclusion information.**



©2017 Sonance. All rights reserved.
Sonance is a registered trademark of Dana Innovations.

Due to continuous product improvement, all features and specifications are subject to change without notice.
For the latest Sonance product specification information visit our website: www.sonance.com

SONANCE • 991 Calle Amanecer • San Clemente, CA 92673 USA
(949) 492-7777 • FAX: (949) 361-5151 • Technical Support: (949) 492-7777
www.sonance.com/outdoor/rocks-mariners-extreme

05.22.17

SONANCE MARINER SERIES

MARINER 86 OUTDOOR SPEAKER



Sonance Mariner Outdoor Speakers

Sonance is pleased to introduce a completely redesigned Mariner line of outdoor loudspeakers. Improving every aspect of the all-weather loudspeaker, the new Mariner line offers best-in-class performance in a sleek contemporary cabinet. The award winning FastMount® bracket system has been updated to match the new aesthetic of the Mariner loudspeaker to ensure the ease of installation you have come to expect from the Mariner line of speakers.

Features & Benefits

Performance

- Completely redesigned woofer, tweeter and crossover with the same materials and technology as our award-winning Visual Performance line
- A 250% increase in woofer excursion allows for significantly decreased distortion at high volumes
- .293" inches (7.44mm) increase in the diameter of the voice coils for increased output and vented pole pieces to decrease heat at voice coils
- Tweeters are chambered allowing for a lower crossover frequency, cooler operation and higher power handling

Aesthetics

- New Black and White color for vastly improved color options
- Paintable cabinets with a clean, minimalistic design

Installation

- The award-winning Mariner outdoor speakers feature IP66 rating allowing for this loudspeaker to be used in the most challenging outdoor environments
- Precision FastMount® mounting bracket simplifies installation, provides up to 180 degrees of pivot and securely locks the speaker into place
- Grille fit has been precision engineered for ease of installation while maintaining grille retention
- Innovative front-mounted wire terminal connections protect against corrosion for a long service life
- Water impermeable drivers and sealed polypropylene enclosure ensure consistent, trouble-free performance

Specifications

SKU	WHITE - 93156 BLACK - 93157
UOM	Pair
Tweeter	1" (25mm) powder-coated aluminum dome, Ferrofluid cooled, in acoustic back chamber
Woofer	8" (203mm) Kevlar/Nomex laminated cone with a Santoprene surround
Frequency Response	45Hz - 20kHz ±3dB
Impedance	8 ohms nominal; 6 ohms minimum
Power Handling	5 watts minimum; 125 watts maximum
Sensitivity	91dB SPL (2.83V/1 meter)
Environmental	Conforms to Mil Spec 810 for humidity, salt spray, temperature and UV, IP-66 waterproof rating
Environment Temp	-13° - 149°F (-25°C - 65°C)
Dimensions (W x H x D)	9.01" x 14.02" x 8.58" (229mm x 356mm x 218mm)
Grille	Perforated aluminum
Shipping Weight	20 lbs. (9kg) pair



Dimensional Sketches Specifications

Mariner 86

Height:	14.02" (356mm)
Width:	9.01" (229mm)
Depth:	8.58" (218mm)

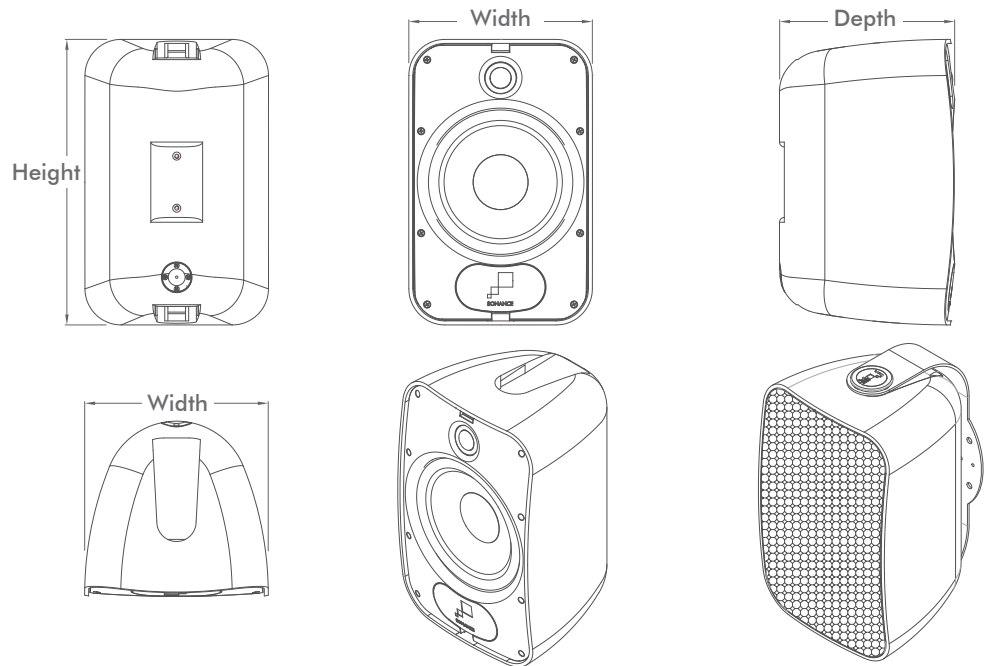

S8 Mounting Bracket

Height:	14.528" (369mm)
Width:	4.527" (115mm)
Depth	
Wall Mount:	9.37" (238mm)
Depth	
Ceiling Mount:	10.315" (262mm)

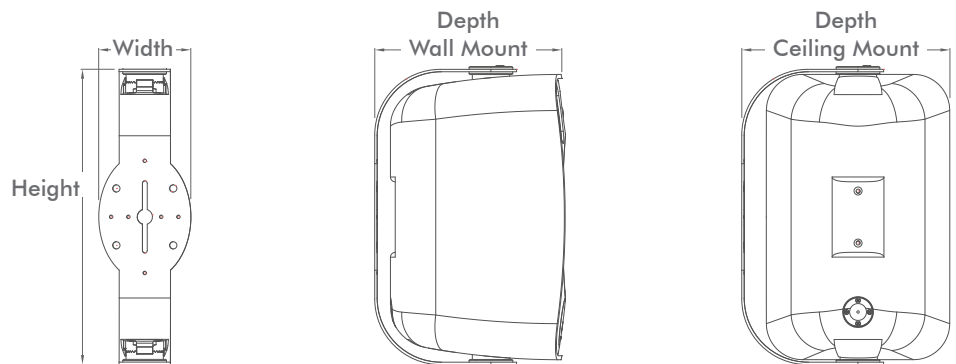

LIMITED FIVE YEAR WARRANTY - Sonance warrants to the first end-user purchaser that this Sonance-brand product (**Mariner 86**), when purchased from an authorized Sonance Dealer/Distributor, will be free from defective workmanship and materials for the life of the Product. Sonance will at its option and expense either repair the defect or replace the Product with a new or remanufactured Product or a reasonable equivalent. **Please visit our website and owner's e-Manual for complete warranty and exclusion information.**



©2017 Sonance. All rights reserved.
Sonance is a registered trademark of Dana Innovations.

Due to continuous product improvement, all features and specifications are subject to change without notice.
For the latest Sonance product specification information visit our website: www.sonance.com

SONANCE • 991 Calle Amanecer • San Clemente, CA 92673 USA
(949) 492-7777 • FAX: (949) 361-5151 • Technical Support: (949) 492-7777
www.sonance.com/outdoor/rocks-mariners-extreme

05.22.17