

QN100B

**Dimensions in millimeters (+ / - 0.1 mm)*

		98"
SET(With stand) (W * H * D)		2176.3 * 1313.5 * 363.3
SET(With stand & With OC) (W * H * D)		2176.3 * 1313.5 * 384.0
SET(Without stand) (W * H2 * D2)		2176.3 * 1244.3 * 19.9
Front Opening Area (A * B * C)		2174.3 * 1227.9 * 2497.1
Wall Mount (a * b)		600 * 400
Packing Out (W * H * D)	W/W	2379 * 1431 * 350
Net Weight (With stand) Kg		83.6
Net Weight (Without stand) Kg		68.6
Gross Weight (W/ Packaging) Kg	W/W	107.9

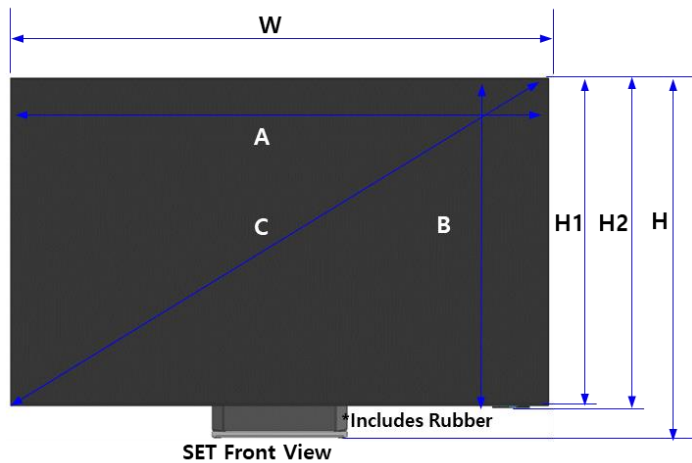

QN100B 98" Set Dimension

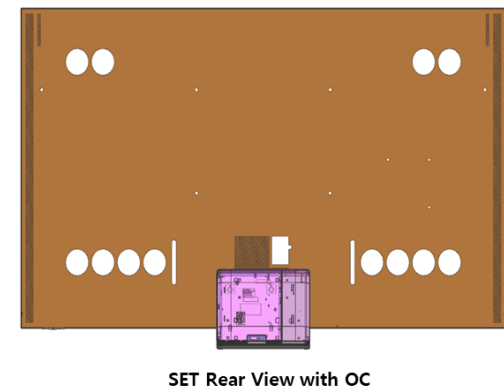
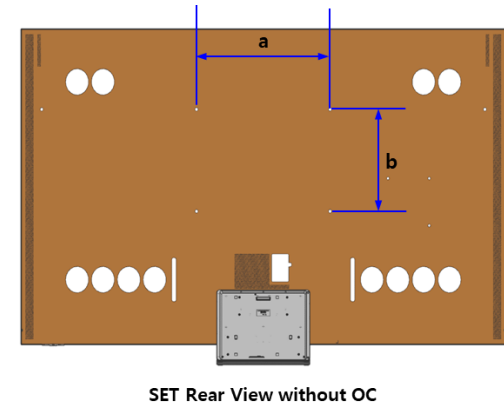
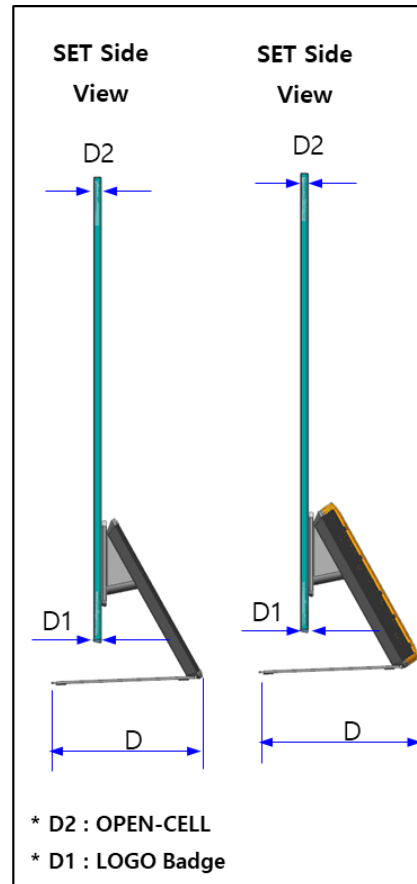

QN100B

**Dimensions in millimeters (+ / - 0.1 mm)*

QN100B Cover and Rear Dimensions

		QN100B
		98"
VESA WALL MOUNT(AXB)		600 X 400
C		788.1
D		315.6
E		523.5
Screw Depth		5-6
SLIM WALL MOUNT	H	315.6
	I	93.1
WALL MOUNT OC	J	586.7
	K	185.0
	L	343.1
	M	

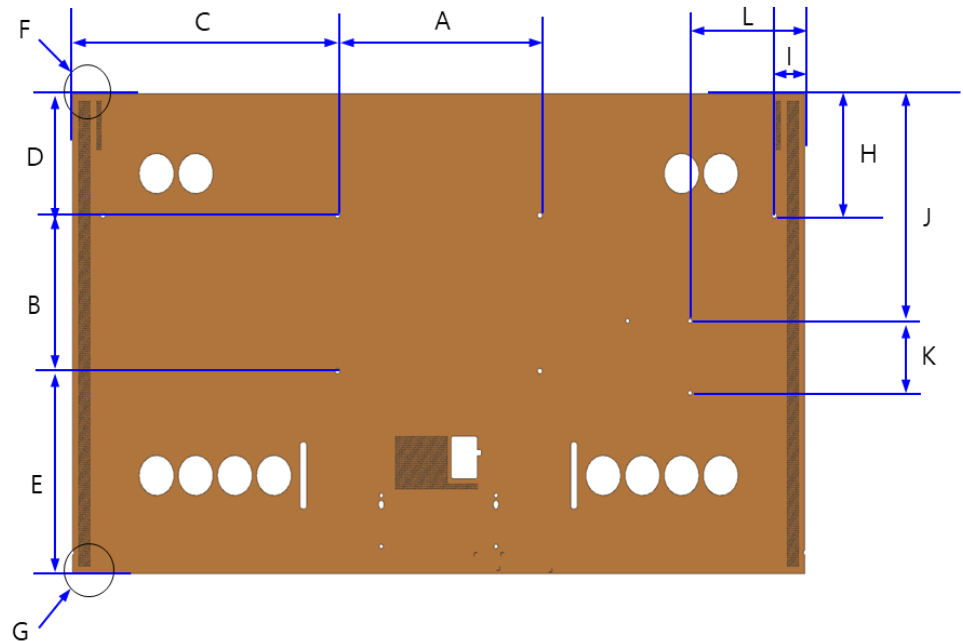

Detail "F"

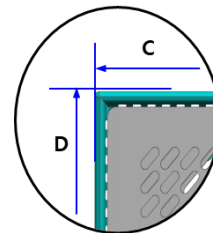

Detail "G"

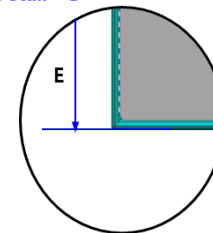

* C,D Dimension based on outer-most dimension
(Chassis-Front & Chassis-Rear)

QN100B

**Dimensions in millimeters (+ / - 0.1 mm)*

QN100B 98" Cover and Rear-View Dimension

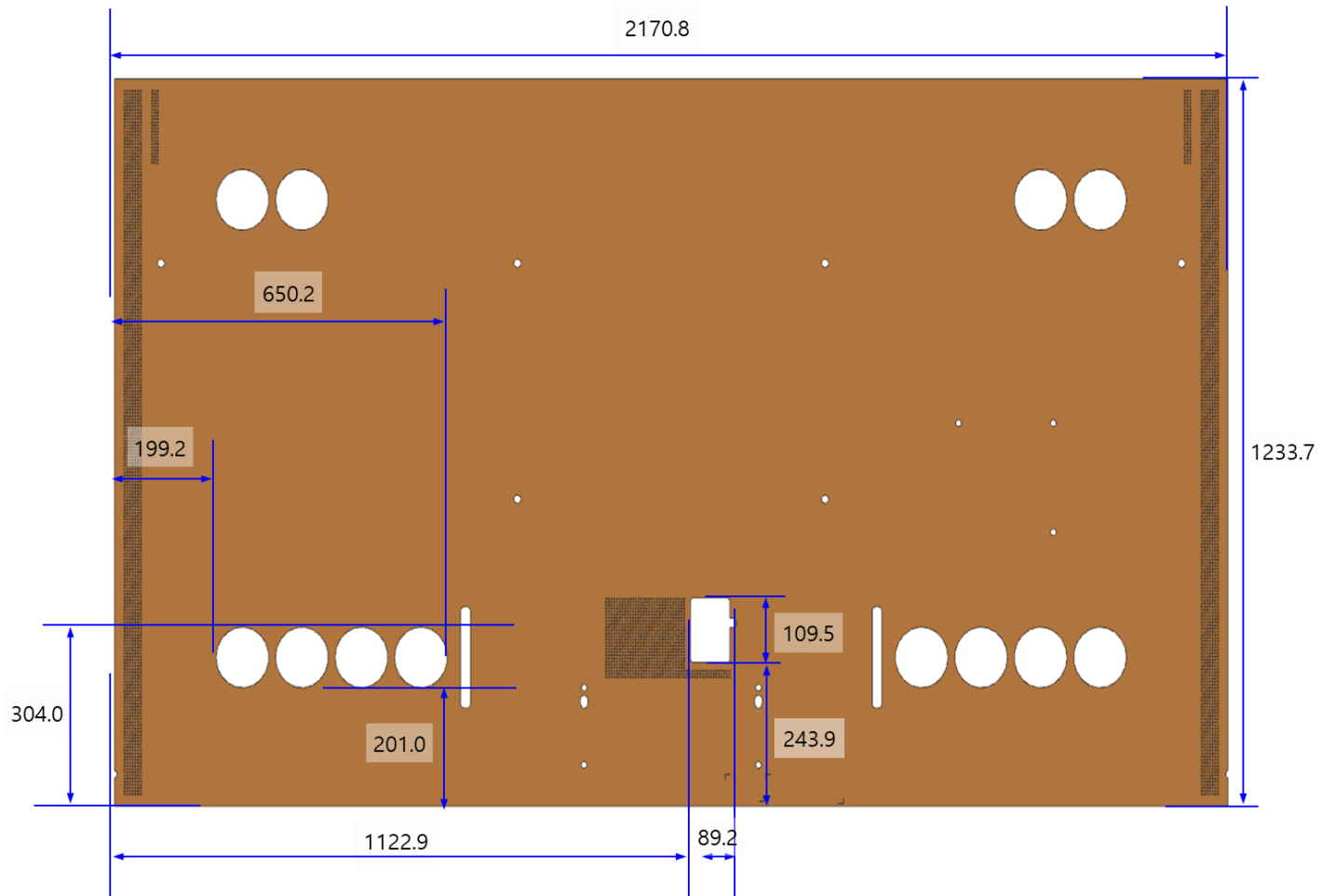

QN100B

**Dimensions in millimeters (+ / - 0.1 mm)*

QN100B 98" Cover and Rear Vent Area

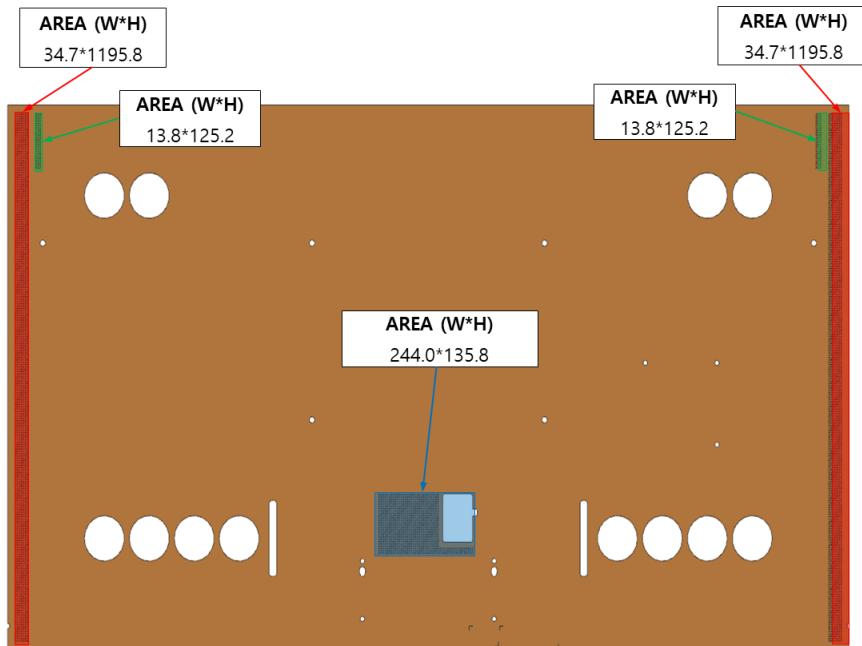

※ VENT (CENTER)

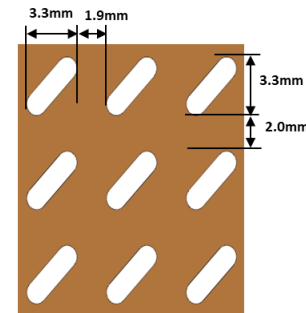

※ VENT (SIDE)

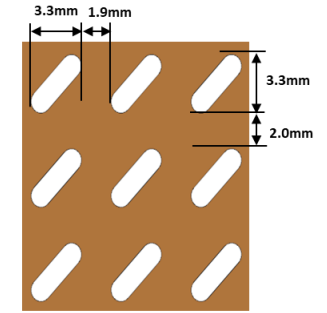

※ VENT (TOP)

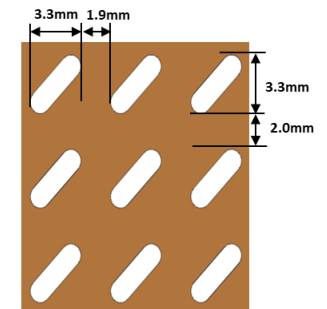

QN100B

**Dimensions in millimeters (+ / - 0.1 mm)*

QN100B Bezel Size

	QN100B	
	98"	
	Top/L/R	Bottom
A	1.0	10.2
B	20.4	

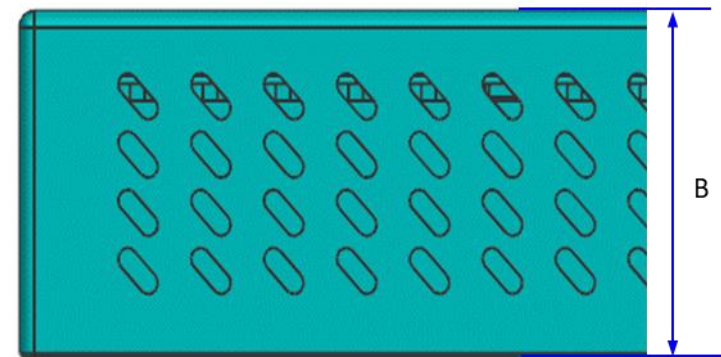
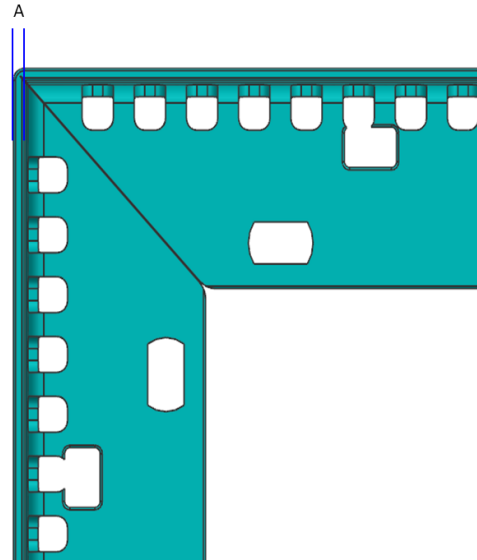

QN100B

**Dimensions in millimeters (+ / - 0.1 mm)*

QN100B Stand Dimension

	QN100B
	98"
CENTER STAND (W*H*D)	420.0 * 288.9 * 363.3

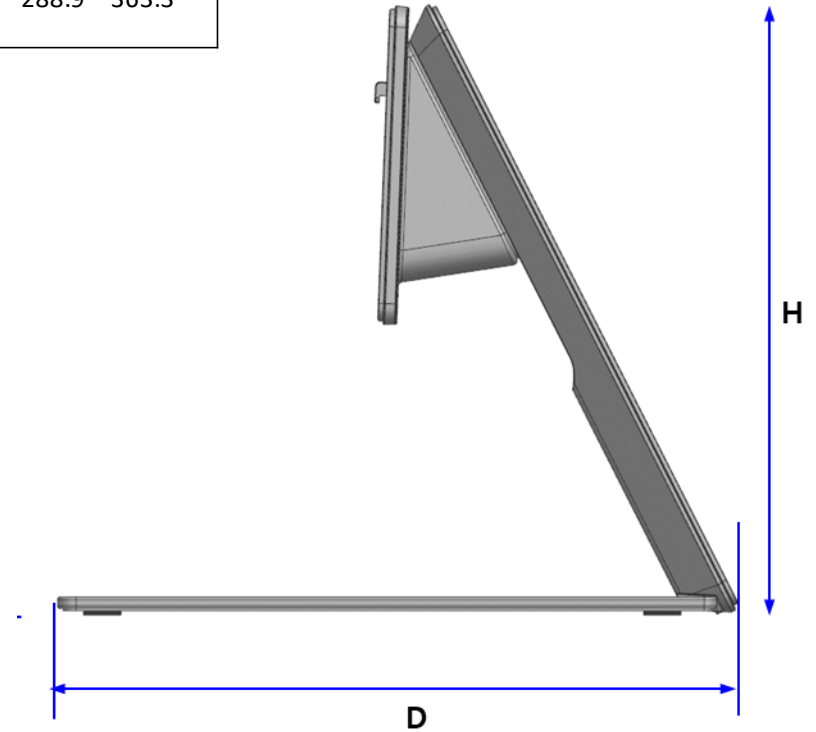
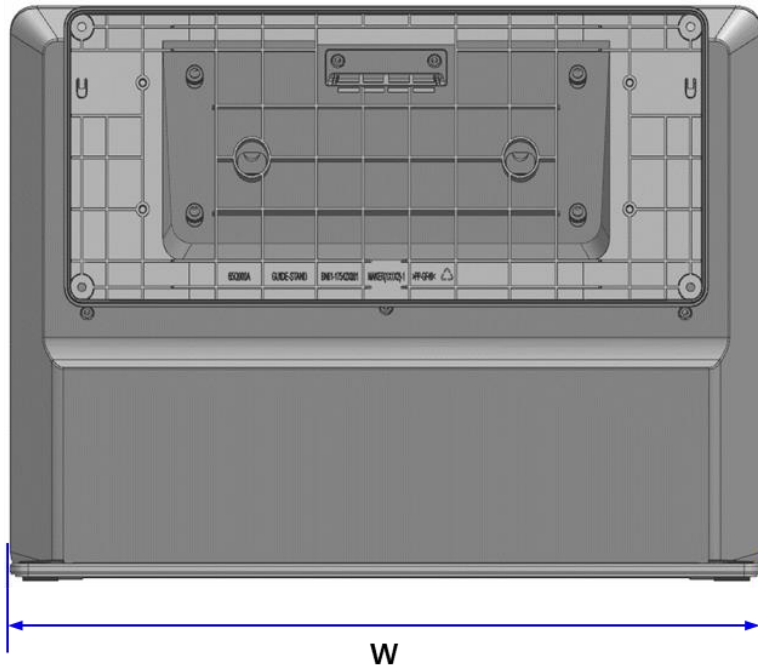

*Includes
Rubber

QN100B

**Dimensions in millimeters (+ / - 0.1 mm)*

QN100B One Connect Box Size

	QN100B
OC BOX (with COVER) (W*H*D)	420.0 * 40.8 * 330.0
OC BOX (without COVER) (W*H*D)	295.0 * 40.8 * 330.0

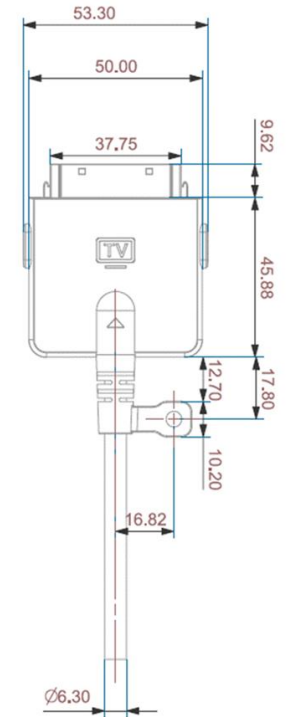
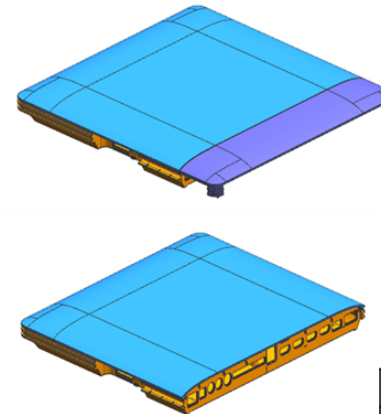
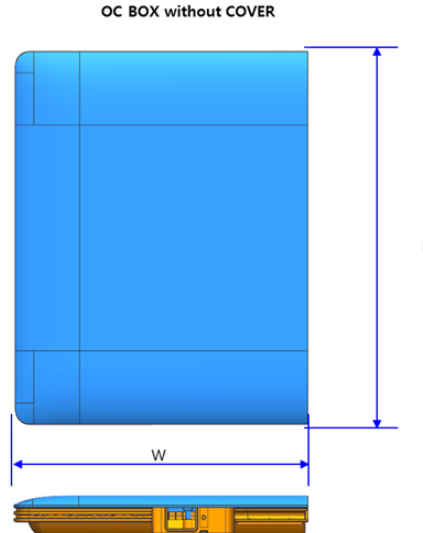
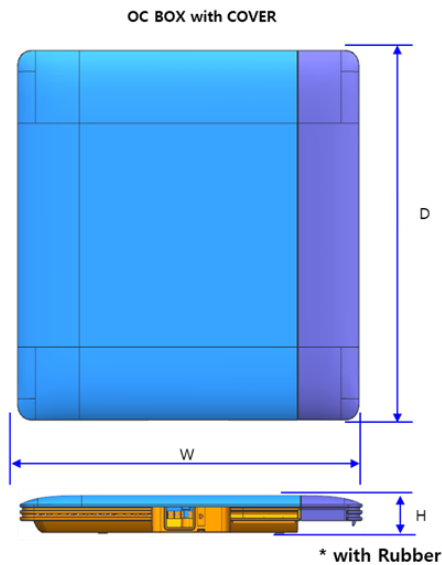

Included OneConnect Cables
0.3M (Short)
2.5M (Long)

QN100B

**Dimensions in millimeters (+ / - 0.1 mm)*

2022 New Model IR Sensor Information

As of Apr/01/2022

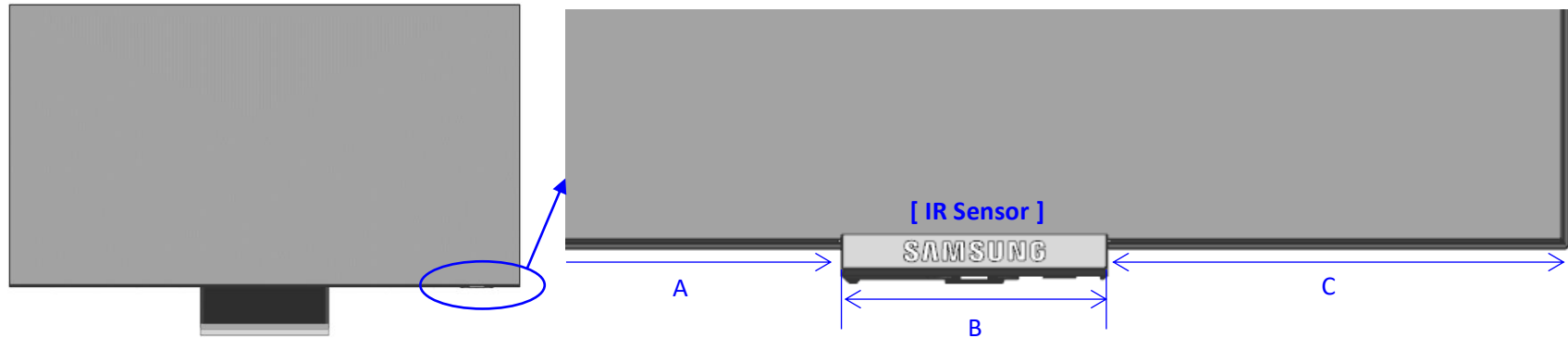

Product	Series	Inch	Item	Sensor Position	DIMENSION		
					A	B	C
Neo QLED 4K	QN100B	98	QN98QN100BFXZA	Right	2019.00	24.70	132.60